

# INSTALLATION INSTRUCTIONS

## CG80UB, CG80RB, & CG80TB

### 80% Gas-Fired Furnace

*Read all instructions in this manual and retain this and all additional instructions for future reference.*

### **WARNING**

Improper installation, adjustment, alteration, service or maintenance can cause injury or property damage. Refer to this manual. For assistance or additional information, consult a qualified installer, service agency, or the gas supplier.

### **WARNING**

Do not store combustible materials, including gasoline and other flammable vapors and liquids, near the furnace, vent pipe, or warm air ducts. The homeowner should be cautioned that the furnace area must not be used as a broom closet or for any other storage purposes. Such uses may result in actions that could cause property damage, personal injury, or death.

### **WARNING**

This furnace is not approved for installation in a mobile home. Do not install this furnace in a mobile home. Installation in a mobile home could result in actions that could cause property damage, personal injury, or death.

### TABLE OF CONTENTS

SAFETY .....	2
INSTALLATION .....	2
START-UP .....	14
OPERATION .....	15
MAINTENANCE .....	17
CONTROL SYSTEM DIAGNOSTICS ..	18
REPAIR PARTS .....	18
WIRING DIAGRAMS .....	19



Manufactured By  
**Allied Air Enterprises Inc.**  
*A Lennox International Inc. Company*  
 215 Metropolitan Drive  
 West Columbia, SC 29170



### **IMPORTANT**

The installation of the furnace, wiring, warm air ducts, venting, etc. must conform to the requirements of the National Fire Protection Association; the National Fuel Gas Code, ANSI Z223.1/NFPA No. 54 (latest edition) and the National Electrical Code, ANSI/NFPA No. 70 (latest edition) in the United States; CSA B149.1 (latest edition) Natural Gas and Propane Installation Codes and the Canadian Electrical Code Part 1, CSA 22.1 (latest edition) in Canada; and any state or provincial laws, local ordinances (including plumbing or wastewater codes), or local gas utility requirements. Local authorities having jurisdiction should be consulted before installation is made. Such applicable regulations or requirements take precedence over the general instructions in this manual.

## IMPORTANT SAFETY INFORMATION

The following is a list of safety rules and precautions that must be followed when installing this furnace.

1. Use only with the type of gas approved for this furnace. Refer to the furnace rating plate.
2. Install this furnace only in a location and position as specified in the **Location** section beginning on page 3 of these instructions.
3. Provide adequate combustion and ventilation air to the furnace space as specified in the **Combustion and Ventilation Air** section beginning on page 4 of these instructions.
4. Combustion products must be discharged outdoors. Connect this furnace to an approved vent system only, as specified in **Venting** beginning on page 6 of these instructions.
5. Never test for gas leaks with an open flame. Use a commercially available soap solution made specifically for the detection of leaks to check all connections, as specified in **Gas Supply and Piping** beginning on page 12 of these instructions.
6. Always install furnace to operate within the furnace's intended temperature rise range with a duct system which has an external static pressure within the allowable range, as specified in **Temperature Rise** on page 16 of these instructions. See furnace rating plate.
7. When a furnace is installed so that the supply ducts carry air circulated by the furnace to areas outside the space containing the furnace, the return air shall also be handled by duct(s) sealed to the furnace casing and terminating outside the space containing the furnace. See **Circulating Air Supply** section beginning on page 8 of these instructions.
8. A gas-fired furnace for installation in a residential garage must be installed as specified in the **Location** section on page 3 of these instructions.
9. The furnace is permitted to be used for temporary heating of buildings or structures under construction as specified in the **Location** section beginning on page 3 of these instructions.

### In the State of Massachusetts:

*This product must be installed by a licensed Plumber or Gas Fitter. When flexible connectors are used, the maximum length shall not exceed 36". When lever-type gas shutoffs are used, they shall be T-handle type.*

## INSTALLATION

**These instructions must be placed on or near the furnace in a conspicuous place.**

This furnace is design certified by CSA International as a Category I furnace using air from inside the structure for combustion. The combustion system is fan-assisted, which means it is equipped with an integral mechanical means to draw products of combustion through the heat exchanger.

CG80TB models may be installed as **upflow** or **horizontal** right to left or left to right airflow furnaces. CG80RB models may be installed as **counterflow** (downflow) or **horizontal** right to left or left to right airflow furnaces. When installed horizontally, the installer must install a sheet metal screw to retain the upper door (see Figure 1).

CG80UB models must be installed only as upflow furnaces.

**Never install any furnace on its back.**

### Inspection of Shipment

***This furnace is shipped in one package, completely assembled and wired.*** The thermostat is shipped in a separate carton when ordered.

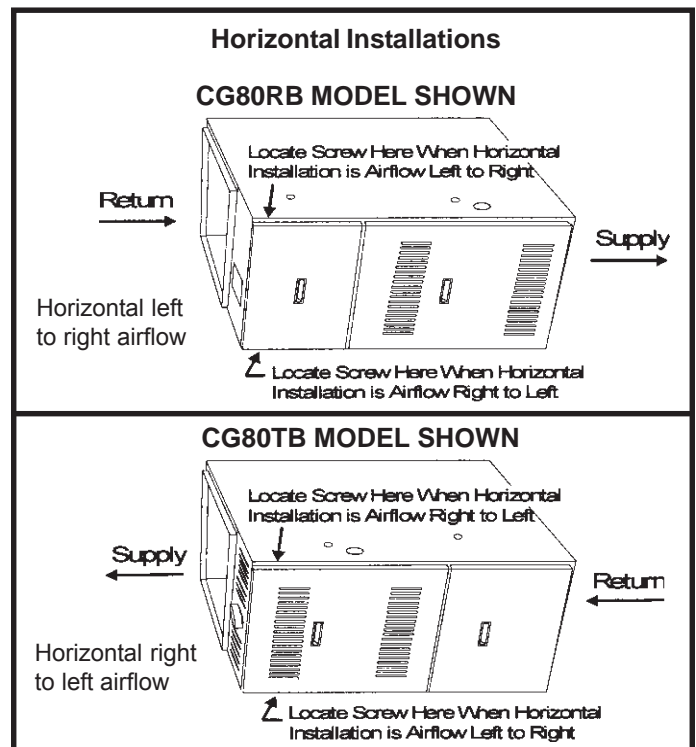

Figure 1

Upon receipt of equipment, carefully inspect it for possible shipping damage. If damage is found, it should be noted on the carrier's freight bill. Damage claims should be filed with the carrier immediately. Claims of shortages should be filed with the seller within 5 days.

Check the rating plate for correct model number, type of gas, and input.

**Clearances**

All servicing and cleaning of the furnace can be performed from the front. If installed in a closet or utility room, provide 18" clearance in front for service if the door to the room is not in line with the front of the furnace.

All models are suitable for installation at reduced clearances to combustibles as noted in the tables in Figure 2. Where servicing clearances are greater than clearances to combustibles, servicing clearances take precedence.

CG80UB, and CG80TB models, and horizontally installed CG80RB models may be installed on wood flooring, but shall not be installed directly on carpeting, tile, or other combustible material other than wood flooring.

CG80RB models installed as counterflow (downflow) units may be installed on combustible flooring provided a special combustible floor base is used. Refer to the **Counterflow (Downflow) Installations** section beginning on page 10 for more information on using the special base assembly.

**Location**

All models are suitable for closet or utility room installation. The furnace must be installed so that electrical components are protected from water.

The furnace is suitable for installation in buildings constructed on-site. The furnace should be centralized in respect to the heat distribution system as much as practicable. When installed in a utility room, the door should be wide enough to allow the largest part of the furnace to enter, or permit the replacement of another appliance, such as a water heater.

A gas-fired furnace for installation in a residential garage must be installed so the burner(s) and the ignition source are located not less than 18" above the floor. The furnace is to be located or protected to avoid physical damage by vehicles.

This furnace is not recommended to be used as a construction heater during any phase of construction. Very low return air temperatures, harmful vapors, and operation of the unit with clogged or misplaced filters will damage the unit.

The furnace may be used for heating of buildings or structures under construction, if the following conditions are met:

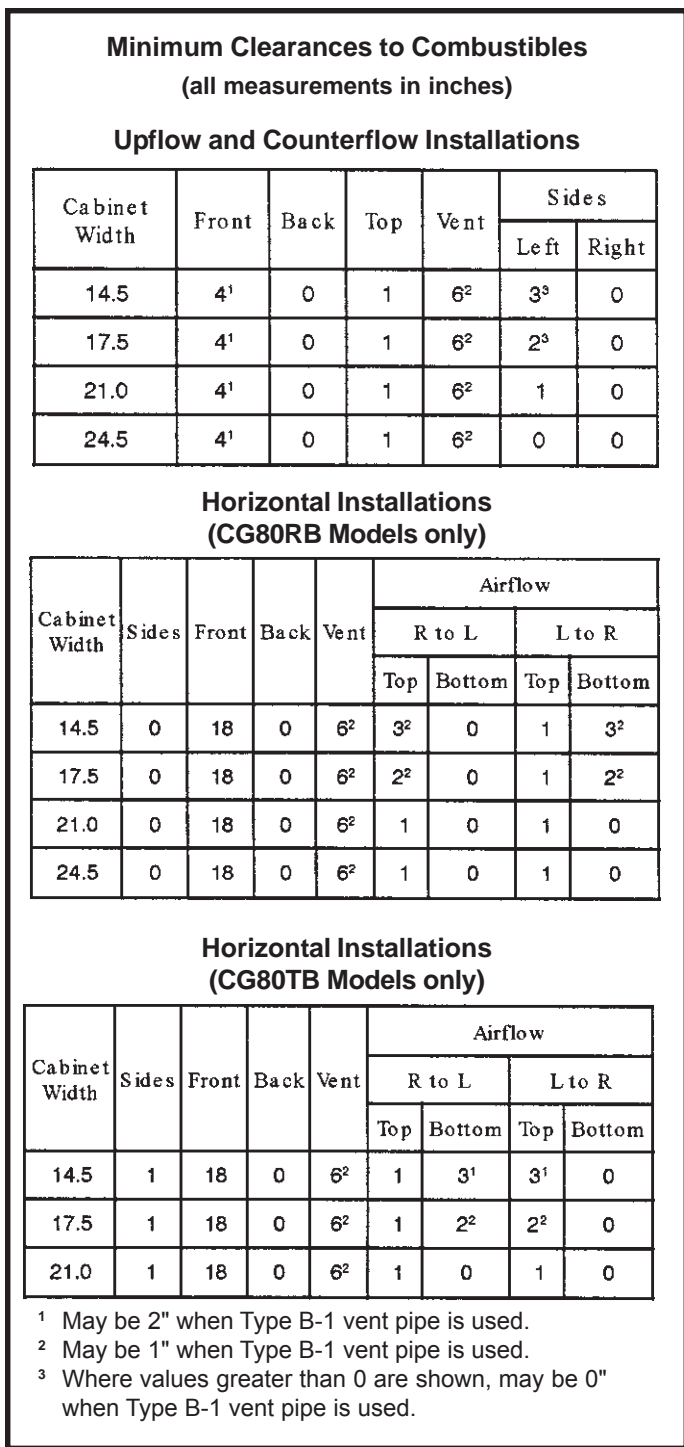

**Figure 2**

- The vent system must be permanently installed per these installation instructions.
- A room thermostat must control the furnace. The use of fixed jumpers that will provide continuous heating is not allowed.
- The return air duct must be provided and sealed to the furnace.

- Return air temperature range between 60°F and 80°F must be maintained.
- Air filters must be installed in the system and must be maintained during construction.
- Air filters must be replaced upon construction completion.
- The input rate and temperature rise must be set per the furnace rating plate.
- One hundred percent (100%) outdoor air must be provided for combustion air requirements during construction. Temporary ducting may supply outdoor air to the furnace. Do not connect duct directly to the furnace. Size the temporary duct following the instructions provided in the next column in the **Combustion and Ventilation Air** section regarding confined space with air from outside.
- The furnace heat exchanger, components, duct system, air filters, and evaporator coils must be thoroughly cleaned following final construction cleanup.
- All furnace operating conditions (including ignition, input rate, temperature rise, and venting) must be verified according to these installation instructions.

CG80RB, and CG80TB models installed in the horizontal position are approved for attic installations. **If the furnace is to be installed in an attic or other insulated space, it must be kept free and clear of insulating materials. When a furnace is installed in conjunction with an evaporator coil in an attic or above a finished ceiling where condensate overflow could result in property damage, a drain pan should be provided under the units as specified by most local building codes.**

CG80RB, and CG80TB models may be installed as suspended units in the horizontal position. These furnaces are not designed for direct attachment of suspension rods to the furnace casing.

The suspending means must be field fabricated, and should consist of two “cradles” made by attaching two rods to a length of angle iron or suitable gage steel. Locate the cradles so that they are as close as possible to the ends of the furnace (this will provide access for removal of major components such as the blower assembly). Provide enough clearance between the suspension rods and the furnace to allow removal of access panels.

### **Combustion and Ventilation Air**

Adequate provisions for combustion air and ventilation of furnace must be made. Refer to Section 5.3, “Air for Combustion and Ventilation,” of the National Fuel Gas Code, ANSI Z223.1/NFPA54 (latest edition), Sections 7.2, 7.3, or

7.4 of CSA B149.1 Natural Gas and Propane Installation Codes (latest editions), or applicable provisions of the local building codes.



### **WARNING**

Air openings in the front of the furnace must be kept free of obstructions. Any obstruction may cause improper operation that can result in a fire hazard or carbon monoxide injury.

### **Unconfined Space**

An unconfined space is defined as “a space whose volume is more than 50 cubic feet per 1000 BTU per hour of the combined input rating of all appliances installed in that space.” When a furnace is installed in an unconfined space in a building, it can be assumed that the infiltration will be sufficient to supply the required air. If the furnace is installed in a ventilated attic or crawl space, it is assumed that the infiltration is sufficient to supply the required air. However, in a building of unusually tight construction, additional outdoor air should be provided.

### **Confined Space**

A confined space is defined as “a space whose volume is less than 50 cubic feet per 1000 BTU per hour of the combined input rating of all appliances installed in that space.”

### **Confined Space Installation/Air from Inside Structure**

If the furnace is installed in a confined space within the building and combustion air is taken from a heated space, the combustion air and ventilating air must enter and leave the space through two permanent openings of equal area. One opening shall be located within 12" of the ceiling and the other within 12" of the floor, each having a free area of 1 square inch per 1000 BTU/HR of total input rating of all appliances within the space and not less than 100 square inches each (see Figure 3).

### **Confined Space Installation/Air from Outside Structure**

If air from outside is brought in for combustion, the confined space shall be provided with two permanent openings. One opening shall be within 12" of the ceiling and one opening within 12" of the floor. Several methods can be used to bring the outside air in through these openings. The openings shall open directly or by ducts with the outdoors, through spaces (crawl space or attic) that freely open to the outdoors, or indirectly through vertical ducts (see Figures 4 and 5). If any of these methods are used, each opening shall have a free area of 1 square inch per 4000 BTU/HR of the total input rating of all appliances within the enclosure.

Another option is to use horizontal combustion ducts (see Figure 6). If horizontal combustion ducts are run, 1 square inch per 2000 BTU/HR is required.

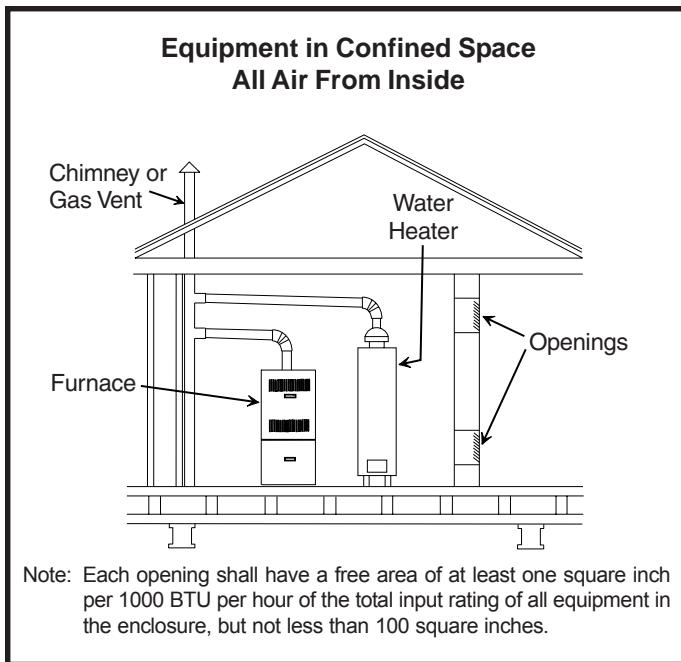

**Figure 3**

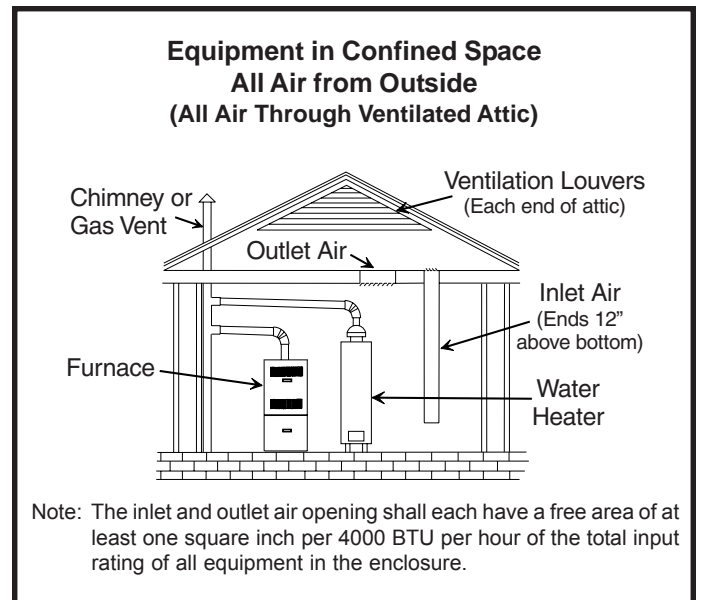

**Figure 5**

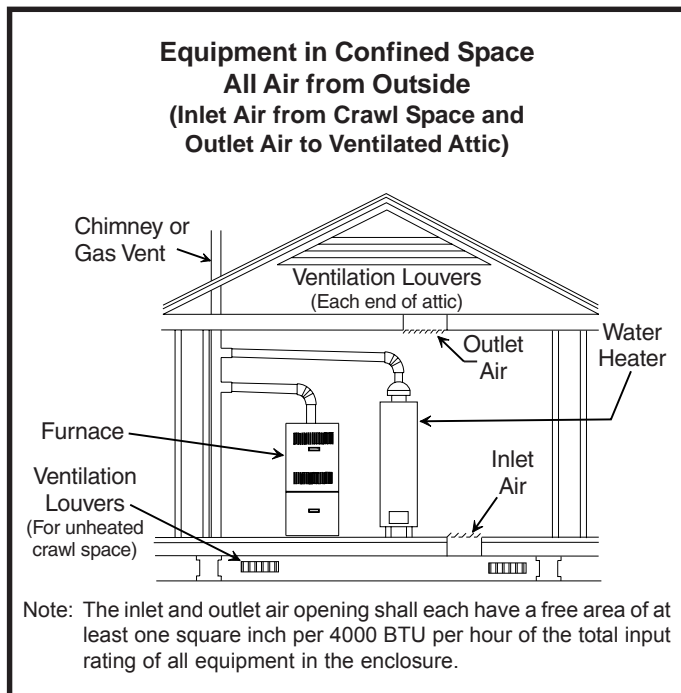

**Figure 4**

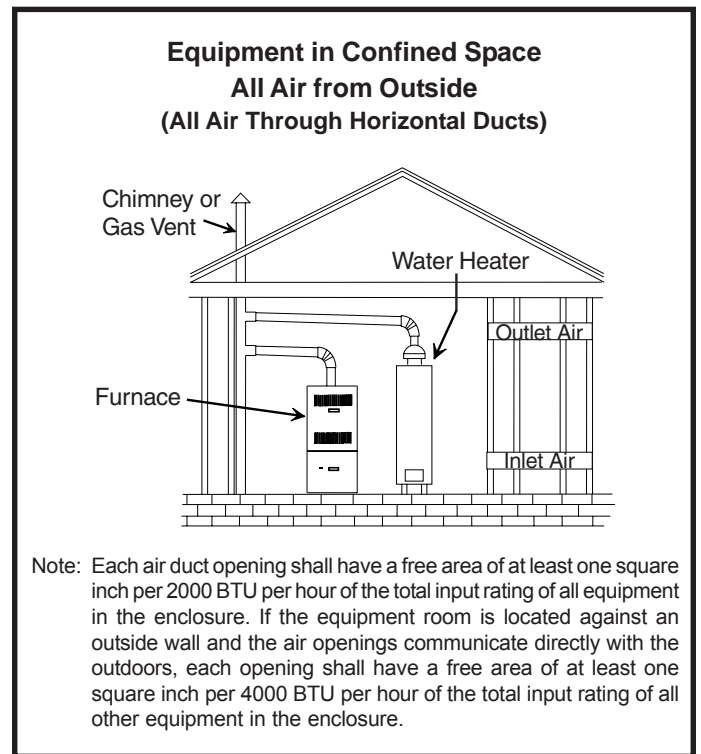

**Figure 6**

**Contaminated Combustion Air**

Excessive exposure to contaminated combustion air will result in safety and performance related problems. The recommended source of combustion air is outdoor air. However, the use of indoor air in most applications is acceptable if the following guidelines are followed:

1. If the furnace is installed in a confined space, it is recommended that the necessary combustion air come from the outdoors by way of an attic, crawl space, air duct, or direct opening.

2. If indoor combustion air is used, there must be no exposure to the substances listed in item 5 (on page 6).
3. All provisions for indoor combustion air must meet the requirements for combustion air indicated in the National Fuel Gas Code, ANSI Z223.1/NFPA 54 (latest edition), and/or any applicable local codes. In Canada, see CSA B149.1, Natural Gas and Propane Installation Codes (latest edition).

4. The following types of installation may require **outdoor air** for combustion, due to chemical exposures:

- Commercial buildings
- Buildings with indoor pools
- Furnaces installed in laundry rooms
- Furnaces installed in hobby or craft rooms
- Furnaces installed near chemical storage areas

5. Exposure to the following substances in the combustion air supply may also require **outdoor air** for combustion:

- Permanent wave solutions
- Chlorinated waxes and cleaners
- Chlorine-based swimming pool chemicals
- Water softening chemicals
- Deicing salts or chemicals
- Carbon tetrachloride
- Halogen-type refrigerants
- Cleaning solvents (such as perchloroethylene)
- Printing inks, paint removers, varnishes, etc.
- Cements and glues
- Antistatic fabric softeners for clothes dryers
- Masonry acid washing materials
- Chlorinated laundry products
- Hydrochloric acid

## Venting

This furnace has a fan-assisted combustion system designed for vertical venting into a suitable chimney or listed gas vent, and is classified as a Category I furnace as shipped from the factory.

**If this furnace is used to replace an existing furnace, it is possible that the existing venting system is not suitable for venting this furnace.** Furthermore, the existing venting system may have to be modified to properly vent any other gas appliance, such as a water heater, that remains connected to it. Carefully read the **Vertical Venting**, **Sidewall Venting**, and **Existing Vent Systems** sections that follow to determine proper venting practices for the installation.

Installation shall be in accordance with Parts 7 and 11 of the National Fuel Gas Code, ANSI Z223.1/NFPA 54 (latest edition) and/or Section 7 and Appendix B of the CSA B149.1, Natural Gas and Propane Installation Codes (latest edition); local building codes; vent manufacturer instructions; and these instructions.



### IMPORTANT

For 100K, 125K, and 150K BTUH input models, the minimum vent connector diameter is 5". The transition from 4" diameter flue outlet to 5" diameter pipe must be made at the flue outlet.

## Vertical Venting

Category I furnaces must be vented vertically or nearly vertically. Common venting and multistory venting are permitted when done in accordance with applicable codes, such as local and national codes.

The venting system should be designed in accordance with the "FAN" columns in the venting tables in the latest editions of the National Fuel Gas Code, ANSI Z223.1/NFPA 54 or the CSA B149.1, Natural Gas and Propane Installation Codes.

1. Consult local building codes for installation requirements.
2. The vent connector should be as short as possible with the least number of elbows and angles to do the job.
3. It is recommended a minimum of 26 gauge galvanized flue pipe be used. Use of single-wall vent pipe for the vent connector is permissible only in conditioned space. **Use Doublewall Type B vent pipe through unconditioned space such as attics and crawl spaces.** The vent material used should be in accordance with the National Fuel Gas Code, ANSI Z223.1/NFPA 54 (latest edition) or the CSA B149.1, Natural Gas and Propane Installation Codes and local codes. Fan-assisted combustion system Category I furnaces shall not be vented into single wall metal vents.
4. The vent connector must have an upward slope toward the chimney on all horizontal runs of at least 1/4" per foot of horizontal run and should be supported by a sheet metal strap. The vent pipe connection must be secured to the induced draft blower outlet. A single screw is sufficient. On CG80RB models, a hole in the door hook will allow access to the blower outlet without removing the door hook.
5. All vents passing through floors, ceilings, and walls must be firestopped according to the requirements of the National Fuel Gas Code (see Figure 7).
6. The furnace shall be connected to a factory-built chimney or vent complying with a recognized standard, or a masonry or concrete chimney lined with a lining material acceptable to the authority with jurisdiction. **Venting into an unlined chimney or a single wall metal vent is prohibited in all cases. A lined chimney may be used if a draft hood equipped appliance, such as a water heater, is connected to the same flue (see Figures 8 and 9).**
7. Extend the vent connector into the chimney so that it is flush with the inside of the flue liner. Seal the joint between the pipe and the liner.
8. Masonry chimneys serving fireplaces cannot be used for venting purposes unless the fireplace opening is permanently sealed.

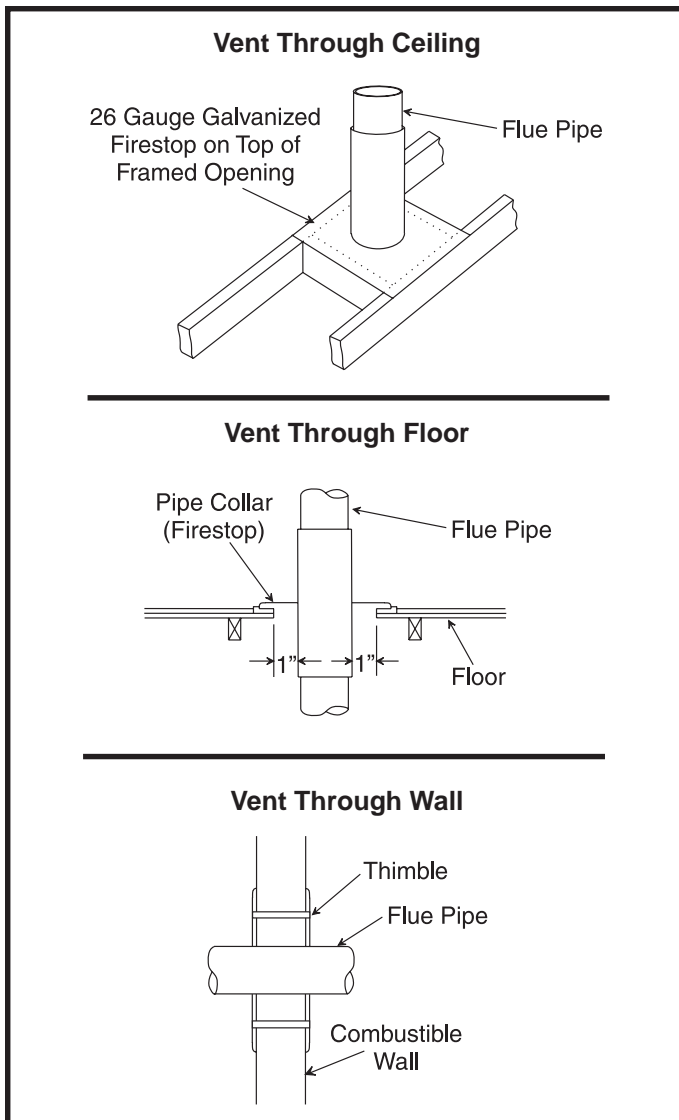

**Figure 7**

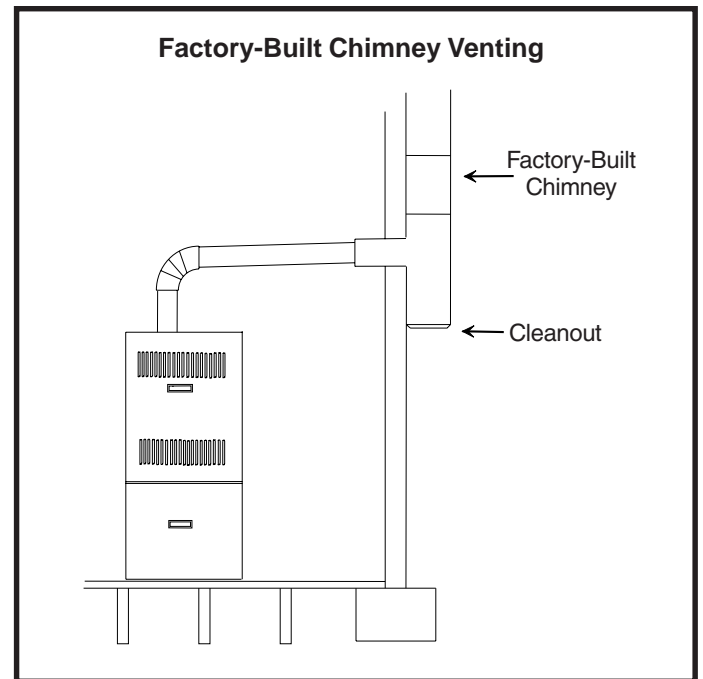

**Figure 8**

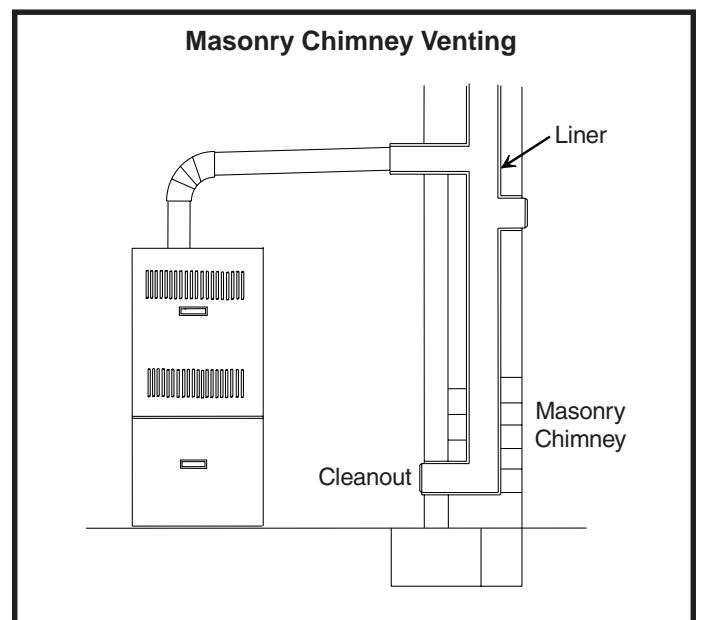

**Figure 9**

9. A vent connector serving this appliance must not be connected into any portion of mechanical draft systems operating under positive pressure.
10. The vent pipe must not be connected to a chimney flue serving a solid fuel appliance.
11. A manual damper, barometric draft regulator, or flue restrictor must not be installed between the furnace and the chimney.
12. Where local experience indicates that condensate may be a problem, the vent shall be constructed to prevent condensation from entering the combustion blower. Provision shall be made to drain off the condensate (see Figures 8 and 9).
13. All unused chimney openings should be closed.

14. All vent pipe run through unconditioned areas or outside shall be constructed of factory-built chimney sections (see Figure 8).
15. Multistory venting is allowed as permitted by the National Fuel Gas Code or local codes.
16. Install all vents in accordance with the vent manufacturer's instructions. For unlisted material, install in accordance with the National Fuel Gas Code.

17. Vent terminals must be installed in accordance with the vent terminals listing or in accordance with the National Fuel Gas Code, ANSI Z223.1/NFPA 54 (latest edition) or the CSA B149.1, Natural Gas and Propane Installation Codes, and local codes.

### **Sidewall Venting**

This furnace can be sidewall (horizontally) vented with a listed sidewall venter, such as Field Controls Model SWG-4HD with CK-43 Control Kit, or Tjernlund Model GPAK-JT. Category I venting classification is maintained when vented in this manner. The furnace, power venter, and control kit (where applicable) must be installed in accordance with their installation instructions and all applicable codes.

The following limitations also apply to the two previously mentioned venters.

Vent pipe diameter:	4"
Minimum vent pipe length:	4'
Maximum vent pipe length:	25' *
Maximum number of 90° elbows:	4

*\* When fewer than four elbows are used, maximum vent pipe length can be increased by 5' per unused elbow.*

**For Canadian installations, only the Field Controls venter and control kit mentioned above are authorized by CSA for use with this furnace.**

See Figure 10 on page 9 for information on where the sidewall vent terminal can and cannot terminate.

### **Existing Venting Systems**

When an existing Category I furnace is removed or replaced, the original venting system may no longer be sized to properly vent the attached appliances. An improperly sized venting system can result in spillage of flue products into the living space, the formation of condensate, leakage, etc. See the **WARNING** box in the next column for proper test procedure.

### **Circulating Air Supply**

When the furnace is installed so that the supply ducts carry air circulated by the furnace to areas outside the space containing the furnace, the return air shall be handled by a duct or ducts sealed to the furnace casing and terminated outside the space containing the furnace.

A return air duct system is recommended. If the unit is installed in a confined space or closet, a return connection must be run, full size, to a location outside the closet. The air duct in the closet must be tight to prevent any entrance of air from the closet into the circulating air.

If there is no complete return air duct system, the return air connection must be sealed to the furnace casing and run full size to a location outside the utility room or space housing the furnace to prevent a negative pressure on the venting system.

## **WARNING**

### **CARBON MONOXIDE POISONING HAZARD**

Failure to follow the steps outlined below for each appliance connected to the venting system being placed into operation could result in carbon monoxide poisoning or death.

The following steps shall be followed for each appliance connected to the venting system being placed into operation, while all other appliances connected to the common venting system are not in operation:

1. Seal any unused openings in the common venting system.
2. Visually inspect the venting system for proper size and horizontal pitch, as required in the National Fuel Gas Code, ANSI Z223.1/NFPA 54 (latest edition) or the CSA B149.1, Natural Gas and Propane Installation Codes and these instructions. Determine that there is no blockage or restriction, leakage, corrosion, or other deficiencies which could cause an unsafe condition.
3. As far as practical, close all building doors and windows between the space in which the appliance(s) connected to the venting system are located and other spaces in the building.
4. Close fireplace dampers.
5. Turn on clothes dryers and any appliance not connected to the venting system. Turn on any exhaust fans, such as range hoods and bathroom exhausts, so they are operating at maximum speed. Do not operate a summer exhaust fan.
6. Follow the lighting instructions. Place the unit being inspected in operation. Adjust the thermostat so appliance is operating continuously.
7. Test for spillage from draft hood equipped appliances at the draft hood relief opening after 5 minutes of main burner operation. Use the flame of a match or candle.
8. If improper venting is observed during any of the above tests, the venting system must be corrected in accordance with the National Fuel Gas Code, ANSI Z223.1/NFPA 54 (latest edition) and/or the CSA B149.1, Natural Gas and Propane Installation Codes.
9. After it has been determined that each appliance remaining connected to the venting system properly vents when tested as outlined above, return doors, windows, exhaust fans, fireplace dampers, and any other gas-fired burning appliance to their previous conditions of use.

## Sidewall Vent Terminal Clearances

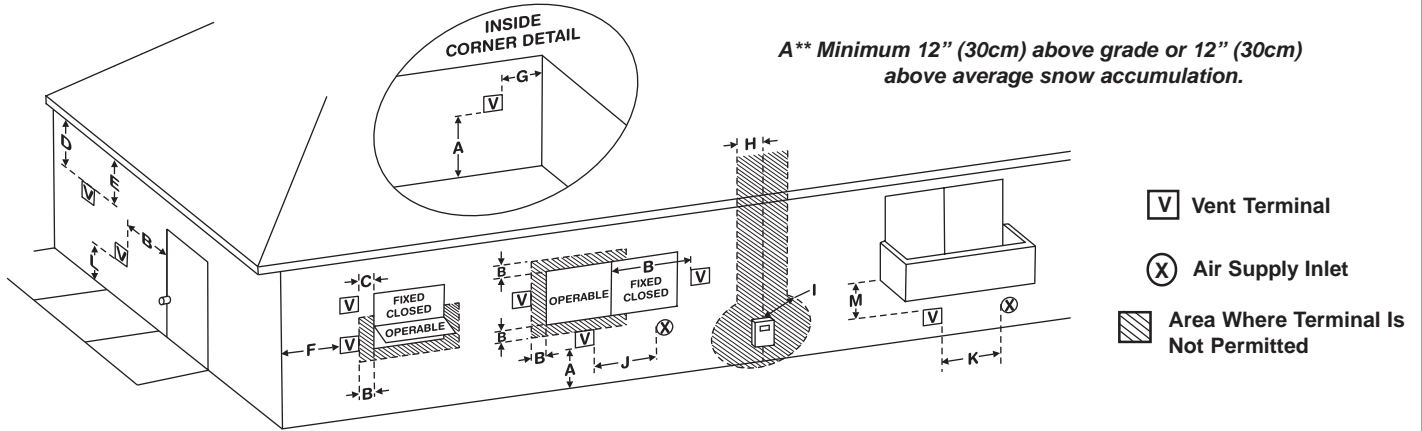

		Canadian Installations <sup>1</sup>	US Installations <sup>2</sup>
<b>A **</b>	Clearance above grade, veranda, porch, deck, or balcony	12 inches (30 cm)	12 inches (30 cm)
<b>B</b>	Clearance to window or door that may be opened	6 inches (15 cm) for appliances ≤ 10,000 Btuh (3 kW), 12 inches (30 cm) for appliances > 10,000 Btuh (3 kW), and ≤ 100,000 Btuh (30 kW), 36 inches (91 cm) for appliances > 100,000 Btuh (30kW)	4 feet (1.2 m) below or to side of opening; 1 foot (30 cm) above opening
<b>C</b>	Clearance to permanently closed window	*	*
<b>D</b>	Vertical clearance to ventilated soffit located above the terminal within a horizontal distance of 2 feet (61 cm) from the center line of the terminal	*	*
<b>E</b>	Clearance to unventilated soffit	*	*
<b>F</b>	Clearance to outside corner	*	*
<b>G</b>	Clearance to inside corner	*	*
<b>H</b>	Clearance to each side of center line extended above meter/regulator assembly	3 feet (91 cm) within a height 15 feet (4.5 m) above the meter/regulator assembly	*
<b>I</b>	Clearance to service regulator vent outlet	3 feet (91 cm)	*
<b>J</b>	Clearance to nonmechanical air supply inlet to building or the combustion air inlet to any other appliance	6 inches (15 cm) for appliances ≤ 10,000 Btuh (3kW), 12 inches (30 cm) for appliances > 10,000 Btuh (3 kW), and ≤ 100,000 Btuh (30 kW), 36 inches (91 cm) for appliances > 100,000 Btuh (30kW)	4 feet (1.2 m) below or to side of opening; 1 foot (30 cm) above opening
<b>K</b>	Clearance to a mechanical air supply inlet	6 feet (1.83 m)	3 feet (91 cm) above if within 10 feet (3 m) horizontally
<b>L</b>	Clearance above paved sidewalk or paved driveway located on public property	7 feet (2.13 m)†	7 feet (2.13 m)†
<b>M</b>	Clearance under veranda, porch, deck, or balcony	12 inches (30 cm) ‡	*

<sup>1</sup> In accordance with the current CSA B149.1, Natural Gas and Propane Installation Code

<sup>2</sup> In accordance with the current ANSI Z223.1/NFPA 54, National Fuel Gas Code

† A vent shall not terminate directly above a sidewalk or paved driveway that is located between two single family dwellings and serves both dwellings.

‡ Permitted only if veranda, porch, deck, or balcony is fully open on a minimum of two sides beneath the floor.

\* For clearances not specified in ANSI Z223.1/NFPA 54 or CSA B149.1, the following statement shall be included:  
 "Clearance in accordance with local installation codes and the requirements of the gas supplier and the manufacturer's installation instructions."

**Figure 10**

When installing a coil in a horizontal position with a horizontal gas furnace, always keep the open end of the A-coil **facing the supply air outlet** of the furnace (blow into the open end of the A-coil). The A-coil should **point away from the supply air outlet** of the furnace (see Figure 11).

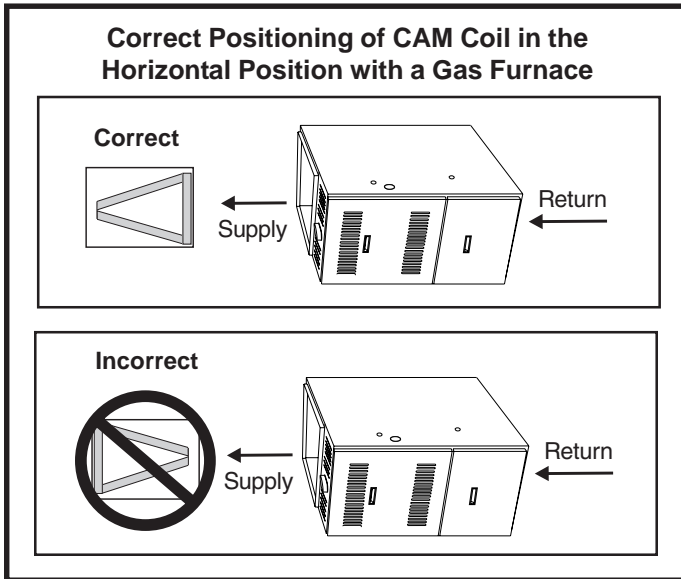

Figure 11

### **! CAUTION**

When an air conditioning unit is used in conjunction with the furnace, the evaporator coil must be installed in the discharge (supply) air. Do not install an evaporator coil in the return air; excessive condensation will occur within the furnace.

If a cooling coil is not installed with the furnace, then a removable access panel should be provided in the supply plenum for purposes of inspecting the heat exchanger. This opening shall be accessible when the furnace is installed, and shall be of such size that the heat exchanger can be viewed for possible openings using light assistance or a probe can be inserted for sampling the air stream. The cover for the opening shall be leaktight.

#### **Upflow Installations**

CG80UB, and CG80TB series furnaces can be installed as upflow units with either a side or bottom air return.

For side return installation, a full-size return air opening must be cut in the side panel. Corner embossments are provided in each side.

For bottom return installation on furnaces with a closed bottom, a full-size return air opening must be cut in the bottom using the corner embossments provided in the bottom panel.

### **! WARNING**

When side return is desired on a furnace with an open bottom, the bottom must be sealed with a piece of sheet metal large enough to cover the entire opening. Failure to connect a return air duct to the bottom, or to enclose the bottom when side return is desired, may result in combustion products being drawn into the circulating air stream which could result in asphyxiation.

To provide sufficient filter area for installations requiring more than 1600 CFM nominal air delivery, return air will have to be brought through both sides of the furnace, through one side and the bottom, or optional filter rack may be used.

#### **Horizontal Installations**

CG80RB, and CG80TB series furnaces can be horizontally installed for airflow right to left or left to right. These furnaces are to be installed so that the burner and blower access panels are in a vertical plane; they are **NOT** to be installed such that these panels are in a horizontal plane (see Figure 1 on page 2).

**Never install any furnace on its back.**

#### **Counterflow (Downflow) Installations**

CG80RB furnaces may be installed directly on the supply plenum or coil cabinet if the furnace is installed on a non-combustible floor.

For installations on combustible flooring, a special base must be ordered and used. (See the Accessories section on page 18 for more information.) To install using the special base assembly, see Figure 12 and the following instructions:

1. Cut a hole in the floor, sized to provide 1" clearance between all four sides of the duct and the edge of the flooring (see Figure 12). The four angles on the base assembly should recess into the floor joists and the base should rest on all four outside flanges.
2. Construct duct connections with 1" to 1-3/4" right angle flanges, and long enough to extend below the floor joists.
3. Drop the duct connections through the top of the base assembly with the right angle flanges in good contact with the glass tape on top of the base assembly.
4. Carefully position furnace over right angle duct flanges.

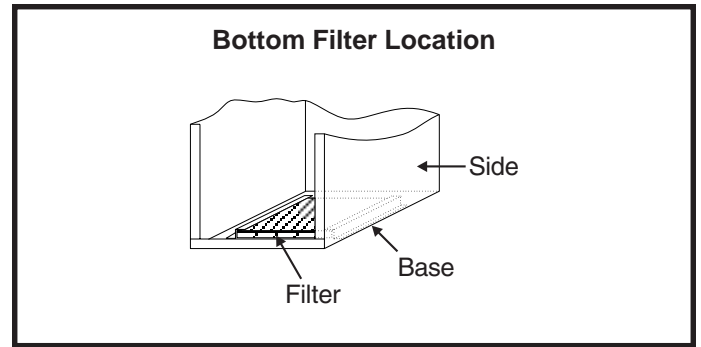
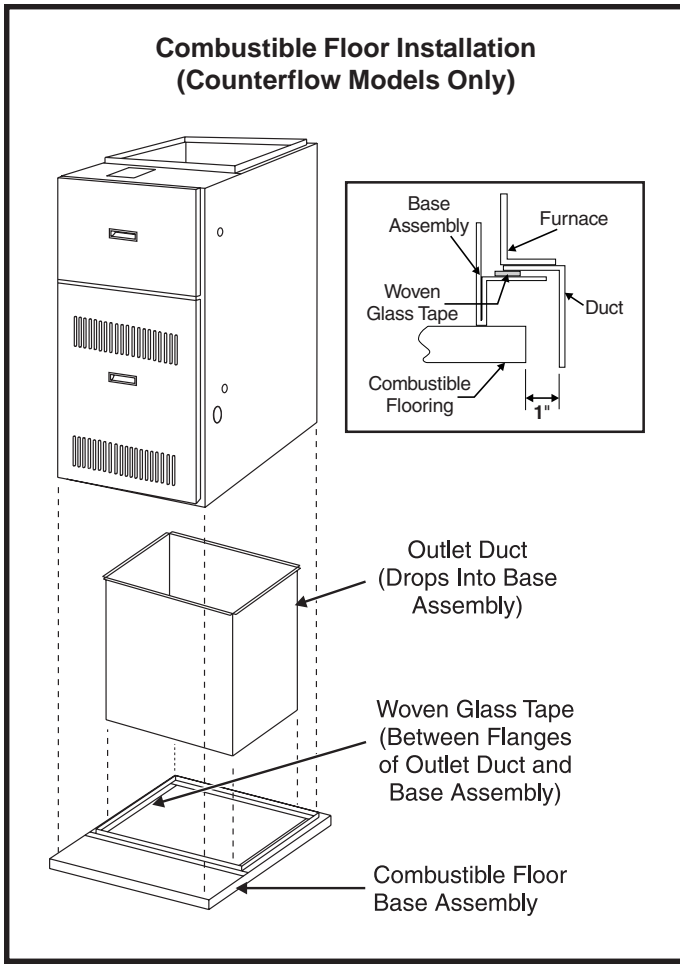

#### Filters

Filters are not supplied with these furnaces since filters are commonly located behind a return grille for ease of servicing. It is the installer's responsibility to install properly sized filters in accordance with Table 1 on this page.

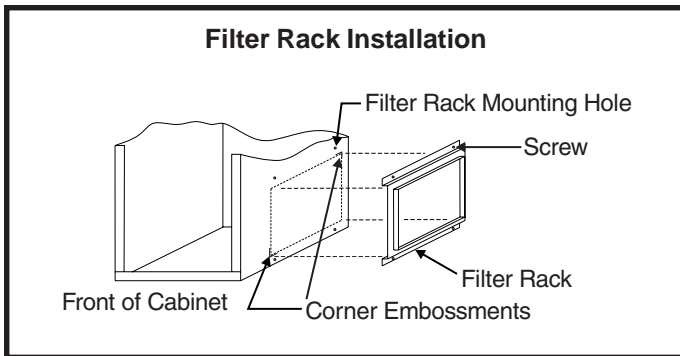

### Minimum Filter Requirements

Airflow Descriptor	Disposable Filters			Cleanable Filters		
	Min. Area (sq. in.)	Size (in.)	Qty.	Min. Area (sq. in.)	Size (in.)	Qty.
09	480	20 x 25	1	240	16 x 20	1
10	480	20 x 25	1	240	16 x 20	1
12	576	16 x 20	2	288	16 x 20	1
14	672	20 x 20	2	336	20 x 20	1
16	768	20 x 20	2	384	20 x 20	1
20	960	20 x 25	2	480	20 x 25	1

1. The Airflow Descriptor is the two digits following the "D" in the model number.
2. Areas and dimensions shown for cleanable filters are based on filters rated at 600 feet per minute face velocity.
3. Typical filter sizes are shown; however, any combination of filters whose area equals or exceeds the minimum area shown is satisfactory.

**Table 1**

## Gas Supply and Piping

Refer to the furnace rating plate to make sure the furnace is equipped to burn the gas supplied (natural or propane).

### WARNING

Any conversion of a natural gas unit to propane gas must be done by qualified personnel using a conversion kit available from the manufacturer, following the instructions in the conversion kit. If done improperly, overfiring of the burners and improper burner operation can result. This can create carbon monoxide which could cause asphyxiation.

### WARNING

When converting a low NO<sub>x</sub> furnace (designated by an "L" in the model number, such as CG80UB100D20CL-1A) to propane, the NO<sub>x</sub> inserts must be removed. Failure to remove the inserts can create a situation where carbon monoxide is produced which may lead to asphyxiation.

To remove the NO<sub>x</sub> inserts, first take out the burners. After removing the burners, remove the screw holding each insert and pull the insert from the combustion chamber (see Figure 15). **The screws must be re-installed in the vest panel after the inserts are removed.**

Gas supply piping should be installed in accordance with local codes and the regulations of the utility. Piping must be of adequate size to prevent undue pressure drop. Consult the local utility or gas supplier for complete details on special requirements for sizing gas piping.

If local codes allow the use of a flexible gas appliance connector, always use a new listed connector. Do not use a connector which has previously serviced another gas appliance.

Pipe connections must be tight, and a non-hardening pipe compound resistant to liquefied petroleum gases should be used.

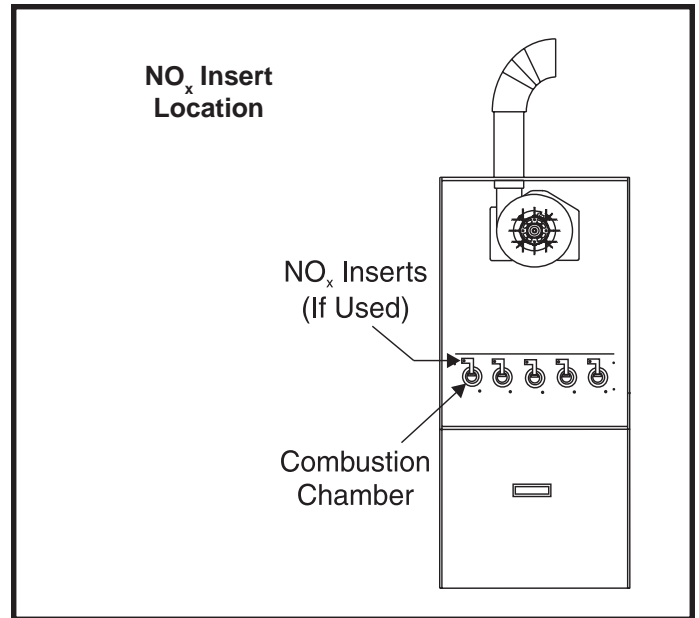

Figure 15

Connect gas pipe to furnace controls providing a ground joint union as close to the controls as is possible to facilitate removal of controls and manifold. Provide a drip leg on the outside of furnace. A manual shutoff valve shall be installed in the gas line, outside the unit, 5' above the floor, or in accordance with any local codes. A test gauge connection must be installed with a 1/8" NPT plugged tapping immediately upstream of the shutoff valve (see Figure 16).

The furnace must be isolated from the gas supply piping system by closing the individual manual shutoff valve during any pressure testing of the gas supply piping system at test pressure equal to or less than 1/2 psig (3.5 kPa) or 14" W.C. If the piping system is to be tested at pressures in excess of 1/2 psig (3.5 kPa), the furnace and its appliance main gas valve must be disconnected from the gas supply piping system.

### WARNING

The gas valve supplied with this furnace is rated at 1/2 psig maximum. Any higher pressure may rupture the pressure regulator diaphragm and may cause overfiring of the burners and improper burner operation. The overfiring may result in the creation of carbon monoxide which could cause asphyxiation.

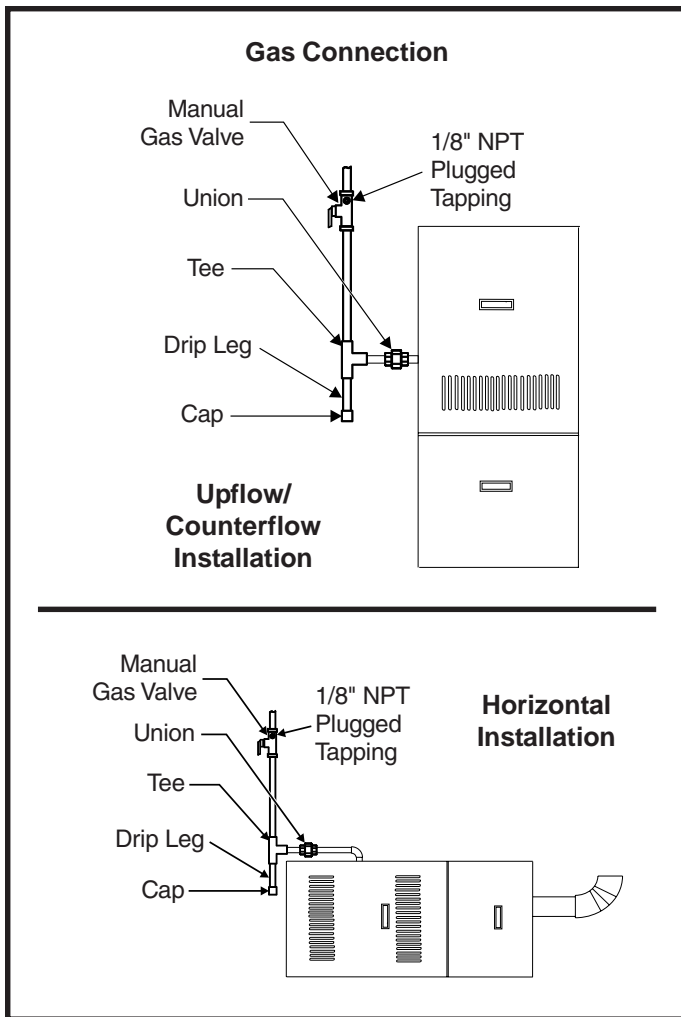

Figure 16

After gas piping is complete, carefully check all piping connections (factory and field) for gas leaks. Use a leak detecting solution or other preferred means. **Some soaps used for leak detection are corrosive to certain metals. Carefully rinse piping thoroughly after leak detection has been completed.**

**⚠ WARNING**

**FIRE OR EXPLOSION HAZARD**

Failure to follow the safety warnings exactly could result in serious injury, death, or property damage.

Never test for gas leaks with an open flame. Use a commercially available soap solution made specifically for the detection of leaks to check all connections. A fire or explosion may result causing property damage, personal injury, or loss of life.

## Electrical Wiring

**⚠ WARNING**

Risk of electrical shock. Disconnect electrical power at the circuit breaker or service panel before making electrical connections. Failure to disconnect power supplies can result in property damage, personal injury, or death.

The furnace must be grounded and wired in accordance with local codes or, in the absence of local codes, with the National Electrical Code ANSI/NFPA No. 70 (latest edition) and/or CSA C22.1 Electrical Code (latest edition) if an external electrical source is utilized.

In all instances, other than wiring for the thermostat, the wiring to be done and any replacement of wire shall conform with the temperature limitation for Type T wire –63°F (35°C) rise.

Connect a sufficiently sized wire with ground to the furnace's line voltage connections and ground lug. Refer to the furnace rating plate for electrical characteristics to be used in sizing field supply wiring and over-current protection.

The line voltage supply should be routed through a readily accessible disconnect located within sight of the furnace. A junction box on the furnace side panel is provided for line voltage connections. Refer to the furnace wiring diagram for specific connection information.

***Proper polarity of the supply connections (“HOT” and “NEUTRAL”) must be observed to ensure that safety controls provide the protection intended.***

A connection to the ground lug and actual earth ground (typically a ground stake or buried steel pipe) must be maintained for proper operation.

### Thermostat

Install a room thermostat according to the instructions furnished with it. Select a location on an inside wall that is not subject to drafts, direct sunshine, or other heat sources. The initial heat anticipator setting should be equal to the total current draw of the control circuit.

Low voltage thermostat connections are to be made to the integrated ignition/blower control board as indicated on the wiring diagram.

### Continuous Blower Operation

If continuous blower operation on low speed is desired, connect the lowest speed motor tap to the “CONT” terminal on the integrated ignition/blower control board (refer to the

furnace wiring diagram.) The blower will operate on low speed whenever main power is connected to the furnace, except when it operates on heating or cooling speed during thermostat call for heat or cooling. **This constant air terminal is intended for low speed only.** If a motor is wired for a higher speed, the increased amp draw could cause the control board to fail and void the warranty.

### Humidifier

Terminals are provided on the integrated ignition/blower control board for connection to a 120-volt humidifier. The "HUM" terminal is energized whenever the thermostat calls for heat. Refer to furnace wiring diagram for specific connection information.

### Electronic Air Cleaner

Terminals are provided on the integrated ignition/blower control board for connection of a 120-volt electronic air cleaner. The "EAC" terminal is energized whenever the thermostat calls for heat, cooling, or continuous blower. Refer to the furnace wiring diagram for specific connection information.

### Twinning

The integrated ignition/blower control board is designed to permit "twinning" of furnaces (two furnaces connected to a common supply and return air system, and controlled by one thermostat). An accessory kit must be ordered from the manufacturer. Specific wiring and operating instructions are included with the kit.

***Each furnace must have its own dedicated vent system.***

## START-UP

### Lighting Instructions

***For Your Safety, Read Before Operating***



### WARNING

If you do not follow these instructions exactly, a fire or explosion may result causing property damage, personal injury, or loss of life.

These furnaces are equipped with an ignition device which automatically lights the burners. **Do not try to light the burners by hand.**

**Before operating**, smell all around the appliance area for gas. Be sure to smell next to the floor because some gas is heavier than air and will settle on the floor.

### What to do if you smell gas:

- Do not try to light any appliances.
- Extinguish any open flame.

- Do not touch any electric switch; do not use any phone in your building.
- Immediately call your gas supplier from a neighbor's phone. Follow the gas supplier's instructions.
- If you cannot reach your gas supplier, call the fire department.

Do not use this furnace if any part has been under water. Immediately call a qualified service technician to inspect the furnace and to replace any part of the control system and gas control which has been under water.

**IMPORTANT: Refer to the Lighting Instruction label on the furnace for instructions on operating the specific controls used on your unit.**

### To Start Furnace:



### CAUTION

Be sure the manual gas control has been in the "OFF" position for at least 5 minutes before starting the unit. Do not attempt to manually light the burners.

1. Set the room thermostat to lowest setting.
2. Remove burner access door.
3. Move the gas control knob or switch to the "ON" position. Use only your hand to turn the gas control knob; never use tools. If the knob will not turn by hand, don't try to repair it; call a qualified service technician. **Force or attempted repair may result in a fire or explosion.**
4. Replace the burner access door.
5. Turn on the electrical power to the furnace.
6. Set the room thermostat to a point above room temperature to light the burners. After the burners have ignited, set the room thermostat to desired temperature.

### To Shut Down Furnace:

1. Set the room thermostat to the lowest setting.
2. Turn off all electric power to the furnace.
3. Remove burner access door.
4. Shut off the gas by moving the gas control knob or switch to the "OFF" position.
5. Replace the burner access door.

## **WARNING**

Should overheating occur or the gas supply fail to shut off, shut off the manual gas valve to the appliance before shutting off the electrical supply.

## **OPERATION**

### **Sequence of Operation**

#### ***Heating***

During a call for heat the thermostat closes the R-W circuit of the control board. The control board verifies limit switches are closed and pressure switch is open. The induced draft blower relay closes causing the blower to run. As vent pressure is developed by the induced draft blower, the pressure switch closes. After a 15-second pre-purge, the control energizes the hot surface ignitor. After the 7-second warmup time, the control energizes the gas valve causing the burners to ignite. The hot surface ignitor is de-energized 3 seconds after the valve opens. If flame is sensed during this time the valve remains energized and the control starts the 30-second heat blower “on” delay.

As heating demand is met, the thermostat de-energizes the R-W circuit. The control de-energizes the valve causing the burners to shut off. The induced draft blower shuts off after a 15-second post-purge delay. The circulating air blower will continue to operate until the user-selectable heat blower “off” delay expires. The control return to standby mode once the heat blower “off” delay expires.

#### ***Fan “On”***

During a fan “on” call, the thermostat energizes the R-G circuit of the control board, immediately causing the fan to energize the heat speed. The fan remains energized as long as the thermostat calls for fan “on” operation.

If a call for heat is energized during a fan “on” call, the fan continues to operate at the heat speed. If a call for cooling is energized during a fan “on” call, the fan switches to cooling speed.

At the end of the fan “on” call the thermostat de-energizes the R-G circuit of the control, causing the fan to be de-energized immediately.

#### ***Cooling***

During a call for cooling, the thermostat energizes the R-Y circuit of the control board. After a 1-second cooling “on” delay, the control energizes the cooling fan speed. If the fan is already energized, it remains running and does not de-energize for the 1-second cooling fan “on” delay.

The call for cooling has priority over continuous fan operation while a call for heating has priority over both a call for cooling or continuous fan. Ignition lockouts for any reason do not affect cooling operation.

As cooling demand is met, the thermostat de-energizes the R-Y circuit of the control board. After a 60-second cooling “off” delay, the control de-energizes the cooling speed fan. At the end of the cooling “off” delay period, the control returns to the standby mode.

### **Controls**

Following is a description of the operation of some of the controls used in this furnace. All models use one of each control, except as noted.

#### ***Pressure Switch***

The pressure switch is a normally open switch that monitors combustion air flow. Inadequate air flow resulting from excessive venting system restriction or a failed combustion blower will cause the switch to remain open.

#### ***Rollout Switch***

The rollout switch is a normally closed switch that opens when abnormal temperatures exist in the burner area. This can be caused by a restricted heat exchanger causing the burner flame to “roll out” into the vestibule area or burner box.

This switch must be manually reset by pushing the button on top to restore furnace operation. CG80RB, and CG80TB series units incorporate two rollout switches.

#### ***Primary Limit Control***

This is a normally closed control that opens if abnormally high circulating air temperatures occur. It is an automatic reset control.

#### ***Auxiliary Limit Control***

This is a normally closed control, located on the circulating air blower housing, that opens under abnormal “reverse air flow” conditions that could occur in a counterflow or horizontal installation if the circulating air blower fails. It is an automatic reset control.

CG80UB models do not include an auxiliary limit control.

#### ***Interlock (Blower Door) Switch***

When the blower door is removed, the interlock switch breaks the power supply to the burner controls and blower motor. The switch operation must be checked to confirm it is operating correctly.

### Integrated Ignition/Blower Control Board

The integrated ignition/blower control board operates all functions of the furnace and any accessories connected to it. These models feature user-selectable blower “off” delay times (60, 90, 120, and 180 seconds) that are factory set to provide a 120-second blower “off” delay on heating (see wiring diagram on page 19).

Refer to the furnace wiring diagram while using the following procedure to change motor speed:

1. Turn off electrical power to the unit.
2. Connect the desired speed tap for cooling on the control board.
3. For heating speed, check the temperature rise and, if necessary, adjust blower speed tap to maintain temperature rise within the range shown on furnace rating plate.

To use the same speed tap for both heating and cooling, install a piggyback terminal on the speed tap using a short jumper. Wire 1/4" quick connect terminals on both ends to jumper the “HEAT” and “COOL” speed on the control board.

4. The remaining speed taps must be connected to dummy terminals marked “PARK” on the control board.

### Checking and Adjusting Gas Input

The minimum permissible gas supply pressure for the purpose of input adjustment is 5" w.c. for natural gas and 11" w.c. for propane gas. This furnace requires conversion for use with propane (see Accessories section on page 18 for correct kit). The maximum inlet gas supply pressure is 10.5" w.c. for natural gas and 13" w.c. for propane.

Gas input must never exceed the value shown on the furnace rating plate. This furnace is equipped for rated input at manifold pressures of 3.5" w.c. for natural gas and 10.0" w.c. for propane gas.

To measure inlet or outlet pressure, remove plug from desired pressure tap (inlet or outlet), as shown in Figure 17, and connect a water manometer or gauge to the proper pressure tap.

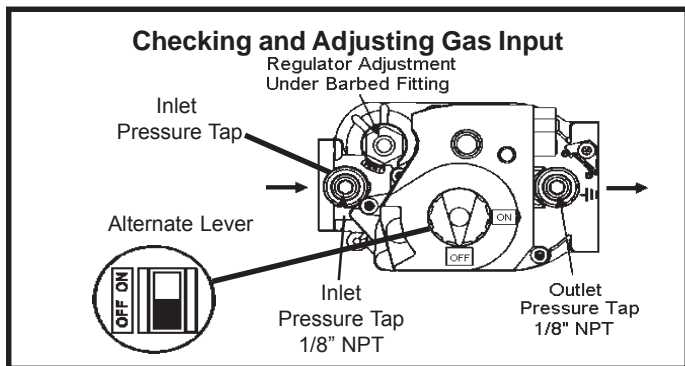

Figure 17

To adjust the regulator, remove the regulator cap and turn the adjusting screw on the regulator clockwise to increase pressure and input; counterclockwise to decrease pressure and input.



### CAUTION

The furnace rate must be within +/- 2% of the appliance rating input.

**For Natural Gas:** Check the furnace rate by observing the gas meter, when available, making sure all other gas appliances are turned off. The test hand on the meter should be timed for at least one revolution. Note the number of seconds for one revolution.

$$\text{BTU/HR} = \frac{\text{Cubic Feet Per Revolution}}{\# \text{ Seconds Per Revolution}} \times 3600 \times \text{Heating Value}$$

The heating value of the gas can be obtained from the local utility company.

**For Propane Gas:** The only check for the furnace rate is to properly adjust the manifold pressure using a manometer and the information provided in Tables 2 and 3. Typical

Manifold Pressure vs. Altitude

Altitude (ft.)	Natural Gas		Propane (LP)		Input Factor
	Heating Value * (Btu/ft <sup>3</sup> )	Manifold Pressure (in. w.c.)	Heating Value * (Btu/ft <sup>3</sup> )	Manifold Pressure (in. w.c.)	
2000	948	3.50	2278	10.00	0.9666
3000	914	3.50	2196	10.00	0.9499
4000	881	3.50	2116	10.00	0.9332
4500	865	3.50	2077	10.00	0.9249
5000	849	3.29	2039	9.41	0.8900
5500	833	3.27	2000	9.35	0.8790
6000	818	3.25	1964	9.29	0.8680
6500	802	3.23	1927	9.24	0.8570
7000	787	3.21	1891	9.18	0.8460
7500	771	3.19	1853	9.12	0.8350

\* Consult local utility for actual heating value.

Furnace Input = Input Factor x Nameplate Input

Above 7500 feet, call Technical Services.

Table 2

manifold set point for installations at altitudes from 0 to 4500 feet above sea level is 10.0" w.c.

### Temperature Rise

Check the temperature rise and, if necessary, adjust blower speed to maintain temperature rise within the range shown on the unit rating plate.

**Manifold Pressure vs. Altitude  
(CG80UB150 only)**

Altitude (ft.)	Natural Gas		Propane (LP)		Input Factor
	Heating Value* (BTU/ft <sup>3</sup> )	Manifold Pressure (in. W.C.)	Heating Value* (BTU/ft <sup>3</sup> )	Manifold Pressure (in. W.C.)	
2000	948	3.41	2278	10.00	0.9666
3000	914	3.41	2196	10.00	0.9499
4000	881	3.41	2116	10.00	0.9332
4500	865	3.41	2077	10.00	0.9249
5000	849	3.20	2039	9.41	0.8900
5500	833	3.18	2000	9.35	0.8790
6000	818	3.16	1964	9.29	0.8680
6500	802	3.14	1927	9.24	0.8570
7000	787	3.12	1891	9.18	0.8460
7500	771	3.11	1853	9.12	0.8350

\* Consult local utility for actual heating value.

Furnace Input = Input Factor x 148,000

Above 7500 feet, call Technical Services.

**Table 3**

**High Altitude**

In both the United States and Canada, this furnace is approved for operation at altitudes from 0 to 4500 feet above sea level without any required modifications. From 4500 to 7500 feet, the gas manifold pressure needs to be adjusted according to the information shown in Tables 2 and 3. To adjust the manifold pressure, refer to previous section **Checking and Adjusting Gas Input**. For installations above 7500 feet, call Technical Service for assistance.

**MAINTENANCE**

**⚠ WARNING**

**ELECTRICAL SHOCK, FIRE,  
OR EXPLOSION HAZARD**

Failure to follow the safety warnings exactly could result in dangerous operation, serious injury, death, or property damage.

Improper servicing could result in dangerous operation, serious injury, death, or property damage.

- Before servicing, disconnect all electrical power to furnace.
- When servicing controls, label all wires prior to disconnecting. Reconnect wires correctly.
- Verify proper operation after servicing.

For installations above 4500 feet fill in the appropriate information on the furnace label that has the words "This furnace was converted on .....".

It is recommended that this furnace be inspected by a qualified service technician at the beginning of each heating season.

**Filters**

Filters should be checked at least every 6 weeks. Disposable filters should be replaced when dirty, and permanent filters should be cleaned regularly. It is important to keep the air filters clean, as dirty filters can restrict airflow and the blower and induced draft motors depend upon sufficient air flowing across and through them to keep from overheating.

**Burners**

Light the burners and allow to operate for a few minutes to establish normal burning conditions. Observe the burner flames. Compare this observation to Figure 18 to determine if proper flame adjustment is present. Flame should be predominantly blue in color and strong in appearance. Check that all burners are lit, and that the flame does not impinge on the sides of the heat exchanger.

Distorted flame or yellow tipping of the natural gas burner flame, or long yellow tips on propane, may be caused by lint accumulation or dirt inside the burner or burner ports, at the air inlet between the burner and manifold pipe, or obstructions over the burner orifice.

Use a soft brush or vacuum to clean the affected areas.

**Lubrication**

The blower motor and induced draft motor are pre-lubricated by the manufacturer and do not require further lubricating attention. However, the motors should be cleaned periodically to prevent the possibility of overheating due to an accumulation of dust and dirt on the windings or on the motor exterior.

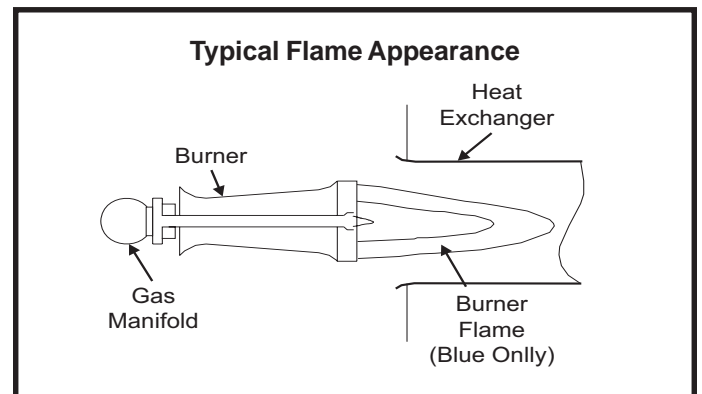

**Figure 18**

# System Sentry™ CONTROL DIAGNOSTICS

## Troubleshooting

Check the following before troubleshooting:

1. Check to see that the power to the furnace and the integrated ignition/blower control board is on.
2. The manual shutoff valves in the gas line to the furnace must be open.
3. Make sure all wiring connections are secure.
4. Review the **Sequence of Operation** (see page 15).

Start the system by setting the thermostat above the room temperature. Observe the system's response. Then use the information provided in this section to check the system's operation.

The furnace has a built-in, self-diagnostic capability. If a system problem occurs, a fault code is shown by an LED on the control board. The control continuously monitors its own operation and the operation of the system. If a failure occurs, the LED will indicate the failure code. The flash codes are presented in Table 4.

Failure Codes	
LED Status	Fault Description
LED Off	No power to control or control hardware fault detected
LED On	Normal operation
1 Flash	Flame Present with gas valve off
2 Flashes	Pressure switch closed with inducer off
3 Flashes	Pressure switch open with inducer on
4 Flashes	High limit switch open
5 Flashes	Rollout switch open
6 Flashes	Pressure switch cycle lockout
7 Flashes	Lockout due to no ignition
8 Flashes	Lockout due to too many flame dropouts
9 Flashes	Incorrect line voltage phasing

**Table 4**

### Fault Code History Button

The control stores the last five fault codes in memory. A pushbutton switch is located on the control (see Figure 19).

When the pushbutton switch is pressed and released, the control flashes the stored fault codes. The most recent fault code is flashed first; the oldest fault code is flashed last. To clear the fault code history, press and hold the pushbutton switch in for more than 5 seconds before releasing.

## REPAIR PARTS

The following repair parts are available from the local distributor. When ordering parts, include the complete furnace model number and serial number which are printed on the rating plate located on the furnace.

### Control Group

Transformer  
 High limit control  
 Auxiliary limit (if used)  
 Gas valve  
 Ignition/blower control board  
 Flame sensor  
 Pressure switch  
 Blower door interlock switch  
 Combustion blower assembly  
 Flame rollout protector switch  
 Hot surface igniter

### Heat Exchanger Group

Heat exchanger  
 Flue box cover  
 Combustion blower transition

### Blower Group

Blower housing assembly  
 Blower wheel  
 Blower mount  
 Blower motor mount  
 Blower motor capacitor

### Burner Group

Gas manifold  
 Burner orifices  
 Burners

## ACCESSORIES

ALPKT572 Natural Gas to Propane Conversion Kit  
 ANGKT557 Propane to Natural Gas Conversion Kit  
 ATWIN579 Twinning Kit  
 ABASE511 Combustible Floor Base (14.5" cabinets)  
 ABASE512 Combustible Floor Base (17.5" cabinets)  
 ABASE568 Combustible Floor Base (21.0" cabinets)  
 ABASE569 Combustible Floor Base (24.5" cabinets)

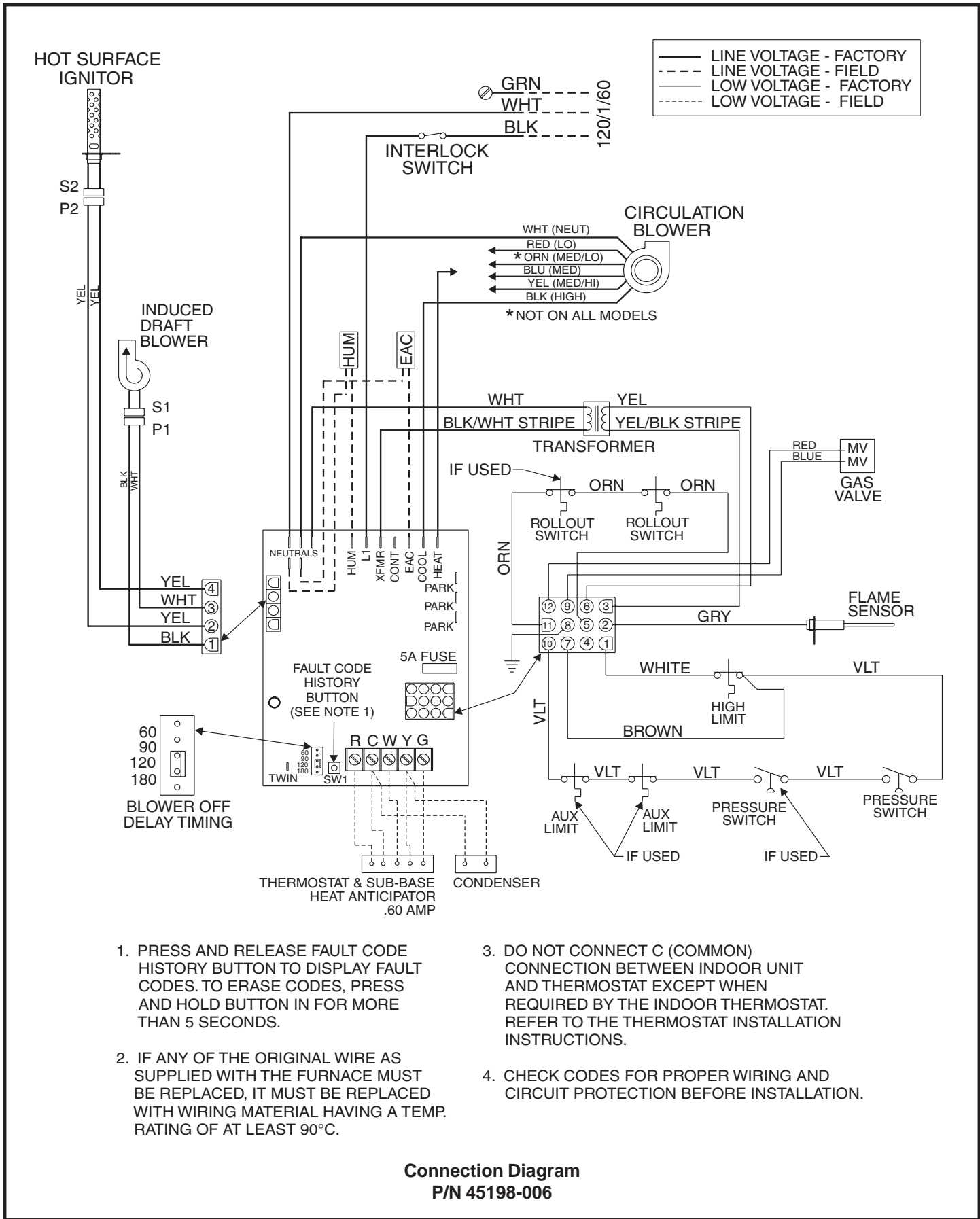
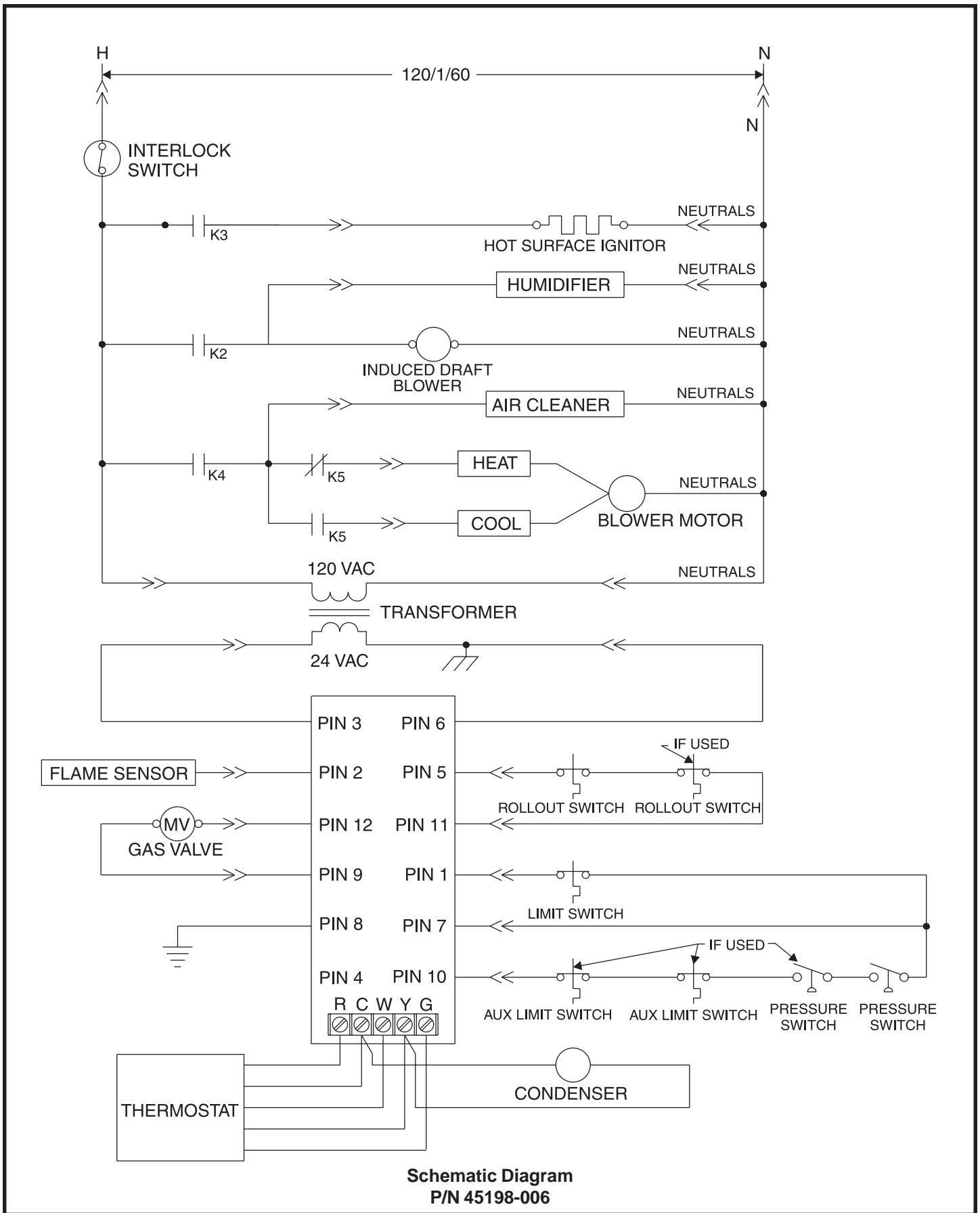

Figure 19



**Schematic Diagram**  
**P/N 45198-006**

**Figure 20**