

RBCS2/BCS2 Series Air Handler Installation Instructions

Table of Contents

AIR HANDLER SAFETY	1	Connect Refrigerant Lines	8
INSTALLATION REQUIREMENTS	2	Make Electrical Connections –	
Tools and Parts	2	Models Without Factory Installed Electric Heat	8
Outdoor System Requirements	2	Make Electrical Connections –	
Location Requirements	2	Models With Factory Installed Electric Heat	9
Installation Configurations	3	Wiring Diagram	11
Drain Pan Connections	4	Complete Installation	12
Electrical Requirements	5	Blower Performance	13
Ductwork Requirements	6	SEQUENCE OF OPERATION	13
INSTALLATION INSTRUCTIONS	6	AIR HANDLER MAINTENANCE	14
Inspect Shipment	6	ASSISTANCE OR SERVICE	14
Install Condensate Drain	7	Accessories	14
Install Ductwork	7	WARRANTY	14
Verify Orifice Size	8		

AIR HANDLER SAFETY

Your safety and the safety of others are very important.

We have provided many important safety messages in this manual and on your appliance. Always read and obey all safety messages.



This is the safety alert symbol.

This symbol alerts you to potential hazards that can kill or hurt you and others.

All safety messages will follow the safety alert symbol and either the word “DANGER” or “WARNING.” These words mean:

⚠ DANGER

You can be killed or seriously injured if you don't immediately follow instructions.

⚠ WARNING

You can be killed or seriously injured if you don't follow instructions.

All safety messages will tell you what the potential hazard is, tell you how to reduce the chance of injury, and tell you what can happen if the instructions are not followed.

INSTALLATION REQUIREMENTS

These instructions are intended as a general guide only and do not supersede any national or local codes in any way. Compliance with all local, state, or national codes pertaining to this type of equipment should be determined prior to installation. Read this entire instruction manual, as well as the instructions supplied in separate equipment, before starting the installation. All models are designed for indoor installation only.

The installation of the air handler, field wiring, warm air ducts, etc. must conform to the requirements of the National Electrical Code, ANSI/NFPA No. 70 (latest edition) in the United States, and any state laws, and local ordinances (including plumbing or wastewater codes). Local authorities having jurisdiction should be consulted before installation is made. Such applicable regulations or requirements take precedence over the general instructions in this manual.

Install the conditioned air plenum, ducts and air filters (not provided) in accordance with NFPA 90B Standard for the Installation of Warm Air Heating and Air-Conditioning Systems (latest edition).

The air handler is provided with flanges for the connection of the plenum and ducts.

Air filters must be listed as Class 2 furnace air filters.

The air handler can be used with R-22 or R410a from the factory.

The air handler is shipped from the factory completely assembled. Some models are configured for upflow air discharge only, and some models are configured for upflow or horizontal left-hand air discharge. The air handler cabinet conforms to 2% or less air leakage.

Do not remove the cabinet knockouts until it has been determined which knockouts will need to be removed for the installation.

Select the final installation position which best suits the site conditions. Consider required clearances, space, and routing requirements for refrigerant line, condensate disposal, filters, ductwork, wiring, and accessibility for service. Refer to the air handler rating plate on the air handler for specific information.

- Adjustable wrench
- Tape Measure
- Hammer
- Sealant

Parts Needed

Check local codes, check existing electrical supply, and read "Ductwork Requirements," and "Electrical Requirements," before purchasing parts.

- UL listed wire nuts
- Refrigerant metering orifice (if needed). See "Verify Orifice Size." The correct orifice size may be contained in the replacement orifice package located inside the control box or the outdoor unit. If this package does not contain the correct orifice for your air handler, you must purchase the correct orifice size.

Outdoor System Requirements

The air handler is designed to match, and must be used with, outdoor units as rated. The indoor sections are manufactured with an interchangeable refrigerant metering orifice to provide optimum refrigerant control and system performance with a variety of different capacities or outdoor units.

In some cases, the rating of the outdoor unit may require that the air handler refrigerant metering orifice be changed or replaced by a thermal expansion valve to obtain rated performance.

Location Requirements

WARNING!

Product contains fiberglass wool. Disturbing the insulation in this product during installation, maintenance or repair will expose you to fiberglass wool. This material may cause respiratory, skin, and eye irritant. Breathing this may cause lung cancer. (Fiberglass wool is known to the State of California to cause cancer.)

Tools and Parts

Gather the required tools and parts before starting installation. Read and follow the instructions provided with any tools listed here.

Tools Needed

- 1/4" nut driver
- Level
- Screwdriver

WARNING



Explosion Hazard

Keep flammable materials and vapors, such as gasoline, away from air handler.

Place air handler so that heating elements are at least 18 inches (46 cm) above the floor for a garage installation.

Failure to follow these instructions can result in death, explosion or fire.

NOTE: When used on cooling applications, excessive sweating may occur when the air handler is installed in a very humid space.

- If installed in an unconditioned space, sealant should be applied around the electrical wires, refrigerant tubing, and condensate lines where they enter the cabinet.
- Electrical wires should be sealed on the inside where they exit the conduit opening. Sealant is required to prevent air leakage into and condensate from forming inside the air handler, control box, and on electrical controls.
- The air handler must be installed in such a way as to allow free access to the coil/filter compartment and blower/control compartment.
- The air handler must be installed with a 3/4" drop in the horizontal position towards the drain pan to ensure proper condensate drainage.

IMPORTANT

The Clean Air Act of 1990 bans the intentional venting of refrigerant (CFC's and HFC's) as of July 1, 1992. Approved methods of reclaiming must be followed. Fines and/or incarceration may be levied for non compliance.

For ease in installation, it is best to make any necessary coil configuration changes before setting air handler in place. See "Installation Configuration Options."

- Upflow air discharge only contains 1 drain pan.
- Upflow or horizontal airflow contains 2 drain pans.

Vertical Installations

Upflow

The air handler must be supported on the bottom only and set on solid floor or field supplied supporting frame. Securely attach the air handler to the floor or supporting frame.

Horizontal Installations

Horizontal installations can be left-hand or right-hand air supply. Adequate support must be provided to ensure cabinet integrity. Ensure that there is adequate room to remove service and access panels if installing in the horizontal position. For correct horizontal coil installation, see "Installation Configuration Options."

IMPORTANT:

- This coil is provided with a secondary drain that should be trapped and piped to a location that will give the occupant a visual warning that the primary drain is clogged. See "Install Condensate Drain."
- When an evaporator coil is installed in an attic or above a finished ceiling, an auxiliary drain pan should be provided under the air handler as specified by most local building codes.

Conversion from Vertical to Horizontal

An upflow only air handler may be converted to horizontal air discharge by installing a horizontal drain pan kit. See "Accessories."

An upflow/horizontal air handler may be converted from horizontal left-hand discharge to horizontal right-hand discharge without additional parts.

Suspended Cabinet Installation

NOTE: Air handlers cannot be installed horizontally lying on or suspended from either the front or back of the air handler. It must be positioned with one side parallel to the floor when in the horizontal position.

The suspending means must be field fabricated, and should consist of 2 "cradles" made by attaching 2 rods to a length of angle iron or suitable gauge steel.

Installation Clearances

Non-Ducted Return Closet Installation

The air handler can be installed in a closet with a false bottom to form a return air plenum or be installed with a return air plenum under the air handler.

Louvers or return air grilles are field supplied. Local codes may limit application of systems without a ducted return to single-story buildings.

- For a unit installed in a closet with a louvered return opening, the minimum open area for the louvers will be
 - 320 square inches for 18 and 24 models
 - 360 square inches for 30 and 36 models
 - 450 square inches for 42, 48 and 60 models
- If the free area is not known, assume a 25% free area for wood or a 75% free area for metal louvers or grilles. Using the louver dimensions and the 25% or 75% assumption, determine if the louver open area meets the minimum open area listed above.
- If the return air plenum is used, the return air grille should be immediately in front of the opening in the plenum to allow for the free flow of return air.
- When not installed in front of the opening, there must be adequate clearance around the air handler to allow for the free flow of return air.

Installation Configurations

Requires drain pan location change

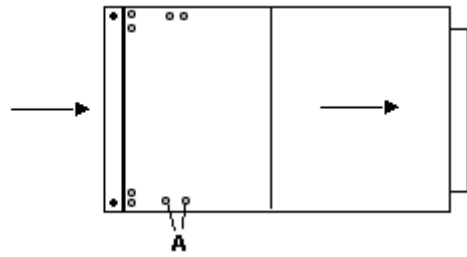

A. Drain connections

Drain Pan Connections

Horizontal Installations can be either "Right" or "Left."

For horizontal right installations, a drain pan location change is required. Use drain connections "A" below.

Installation Configuration Options

Shading indicates proper line connections

Upflow

As shipped from the factory
(return in bottom)

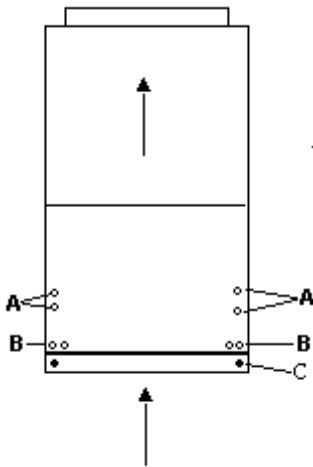

A. Horizontal drain connections
(left or right hand)

B. Upflow drain connections
C. Bottom/filter frame

Horizontal Right
Requires drain pan location change

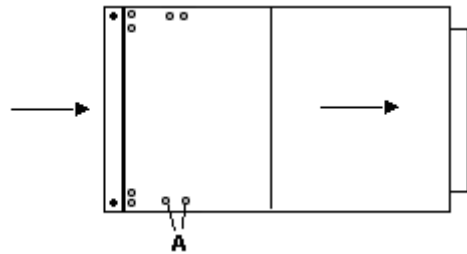

For horizontal left installations, use drain connections marked "A" below.

Horizontal Left
Factory ready (on some models)

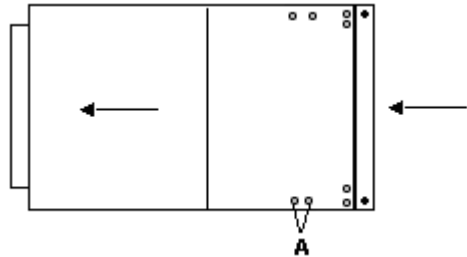

Follow the steps here to modify your drain pan for horizontal right configuration.

Horizontal Left
Factory ready (on some models)

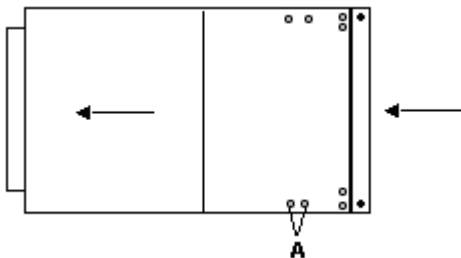

A. Drain connections

Horizontal Right

Before Conversion

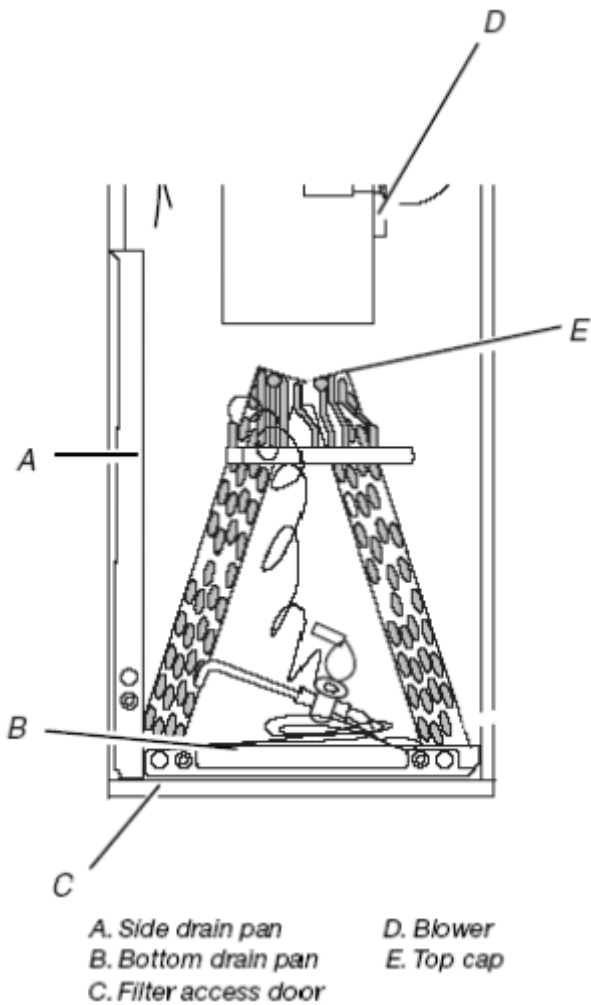

1. Remove and set aside blower and coil access covers.
2. Remove the coil support bracket.
3. Remove coil assembly, bottom drain pan and side drain pan as one assembly from the air handler.

Caution: equipment damage, or personal injury. Take care when removing coil assembly from unit. Installation in this configuration may cause the coil to tip into unit once clear of the cabinet. Support the coil when removing.

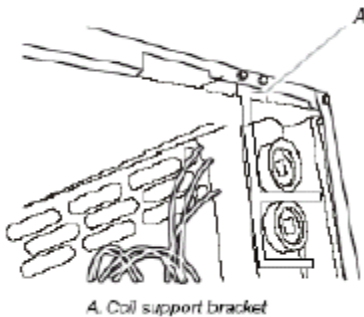

4. Move side drain pan to the opposite side
5. Install modified coil assembly back into air handler in the same orientation as before.
6. Install the coil support bracket on the opposite side of the air handler.

NOTE: For models 2.5 thru 5 ton the bracket attached to the top plate will need to be switched to the opposite side of the coil. This is to prevent blowoff in the horizontal position when the airflow is changed from left hand to right hand.

After Conversion

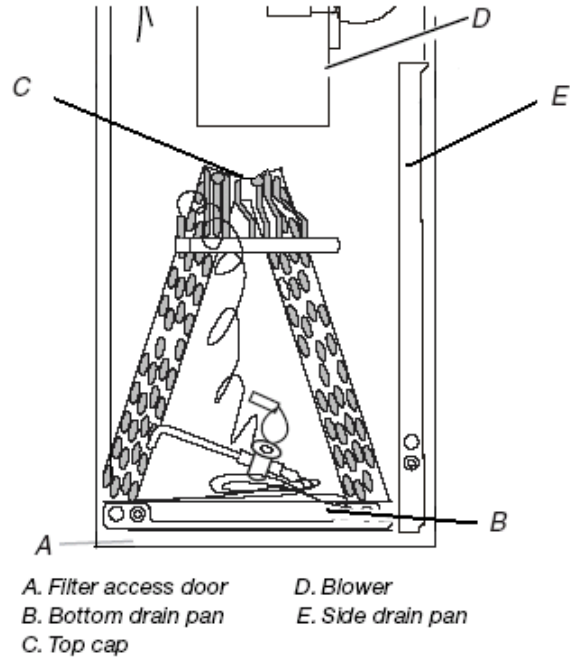

7. Determine knockouts required for drain line connections. Knock out and install drain lines.
8. Replace the blower and coil access covers.

Electrical Requirements

⚠ WARNING

Electrical Shock Hazard

Electrically ground electric heater.
Connect ground wire to ground terminal marked "GND."
Use copper wire rated for supply connection.
Correct wire gauge is shown in the chart below.
Failure to follow these instructions can result in death or electrical shock.

Rating Plate Ampacity	AWG
21 - 30	10
31 - 40	8
41 - 60	6

NOTE: Use copper conductors only.

- All field wiring must be done in accordance with National Electrical Code, applicable requirements of UL and local codes, where applicable.
- Electrical wiring, disconnect means and over-current protection are to be supplied by the installer. Refer to the air handler rating plate for maximum over-current protection, minimum circuit ampacity, as well as operating voltage.
- The power supply must be sized and protected according to the specifications supplied on the product.
- This air handler is factory-configured for 240 volt, single phase, 60 cycles. For 208-volt applications, see "208 Volt Conversion" in the "Make Electrical Connections" section.
- For optional electric heater applications, see "Accessories." Refer to the instructions provided with the instructions provided with the accessory for proper installation (**Models without Factory-installed electric heat only**).

Ductwork Requirements

- Install the conditioned air plenum, ducts and air filters (not provided) in accordance with NFPA 90B Standard for the installation of Warm Air Heating and Air-Conditioning Systems (latest edition).
- The air handler is provided with flanges for the connection of the plenum and ducts.
- The air handler is equipped with flanges that can form a filter rack for the installation of the air filter, or the filter may be installed as part of the return air duct system.
- Air filters must be listed as Class 2 furnace air filters.
- Supply and return ductwork must be adequately sized to meet the system's air requirements and static pressure capabilities. Ductwork should be insulated with a minimum of 1" thick insulation with a vapor barrier in conditioned areas or 2" minimum in unconditioned areas.
- Supply plenum should be the same size as the flanged opening provided around the blower outlet and should extend ideally at least 3 ft. from the air handler before turning or branching off plenum into duct runs. The plenum forms an extension of the blower housing and minimizes air expansion losses from the blower.

INSTALLATION INSTRUCTIONS

Inspect Shipment

! WARNING

Excessive Weight Hazard

Use two or more people to move and install air handler. Failure to do so can result in back or other injury.

These air handlers are completely factory assembled, and all components are performance tested. Each unit consists of a blower assembly, refrigerant coil, and controls, in an insulated galvanized steel factory finished enclosure. Knockouts are provided for electrical wiring entrance.

1. Check the unit rating plate to confirm specifications are as ordered.
2. Upon receipt of equipment, thoroughly inspect it for possible shipping damage. Closely examine the unit inside the carton if the carton is damaged.
3. If damage is found, it should be noted on the carrier's freight bill. Damage claims should be filed with carrier immediately. Claims of shortages should be filed with the seller within 5 days.

NOTE: If any damages are discovered and reported to the carrier, do not install the unit because your claim may be denied.

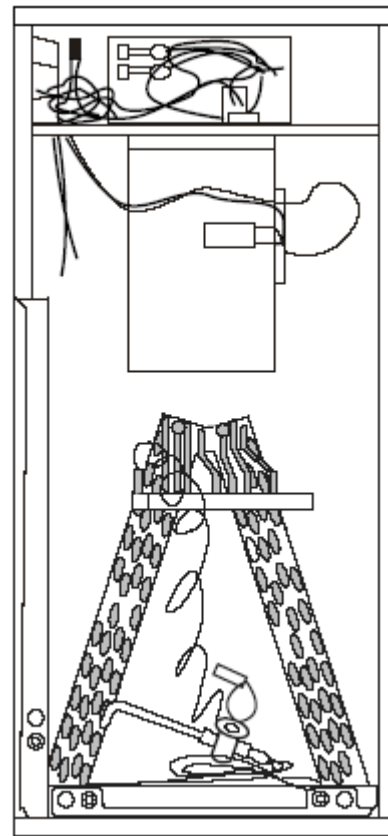

If a filter is to be installed at the air handler, a filter rack must be formed using factory-supplied flanges.

1. Lay air handler on its back
2. Pry filter rack tabs out.

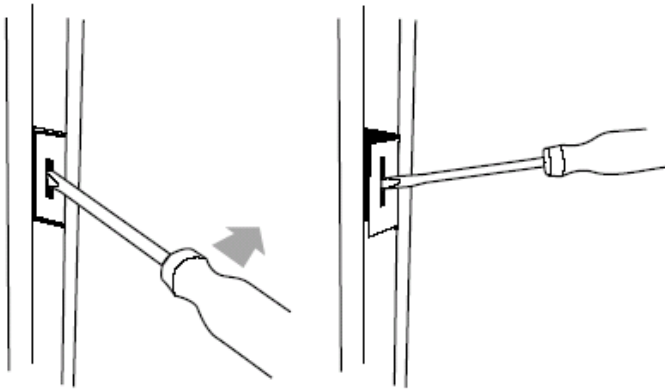

3. Place air handler in vertical position.

IMPORTANT

Filter access panel must be in place during unit operation. Excessive warm air entering the unit may result in water blow off problems.

Filter Size Chart

Model	Filter Size
18 / 24	16" X 20"
30 / 36	18" X 20"
42/ 48 / 60	18" X 25"

Install Condensate Drain

The air handler is provided with 3/4" NPT condensate drain connections.

A field-fabricated secondary drain pan, with a drainpipe to the outside of the building, is required in all installations over a finished living space or in any area that may be damaged by overflow from the main drain pan. In some localities, local codes may require a secondary drain pan for any horizontal installation. Make sure unit is level so that the drain pan will empty completely without water standing in the pan.

1. Remove the appropriate drain knockouts. See "Drain Pan Connections" section. You may need to remove the indoor coil assembly from the cabinet.
2. Remove any web from inside any threaded drain pan hole to which a drain line is to be connected. Gently remove the web so as not to damage the coil.
3. Connect primary drain line connection to the primary drain pan connection. The primary drain connection is flush with the bottom of the inside of the pan.

NOTE: When making drain fitting connections to the drain pan, hand tighten. Using a sealant is recommended. Over tightening the fittings can split connections on the drain pan.

4. Secondary drain connections, if used, should be connected to a separate drainage system. Run the

secondary drain line to a place where the occupant would notice if water started coming from the secondary pan.

5. Install a 3" trap in both the primary and secondary drain lines as close to the unit as practical. Make sure the top of the trap is below the connection to the drain pan to allow complete drainage of the pan.

NOTE: Horizontal runs must also have an anti-siphon air vent (standpipe) installed ahead of the horizontal run. See "Typical Condensate Drain Connection." An extremely long horizontal run may require an oversized drain line to eliminate air trapping.

Typical Condensate Drain Connection (secondary drain not shown)

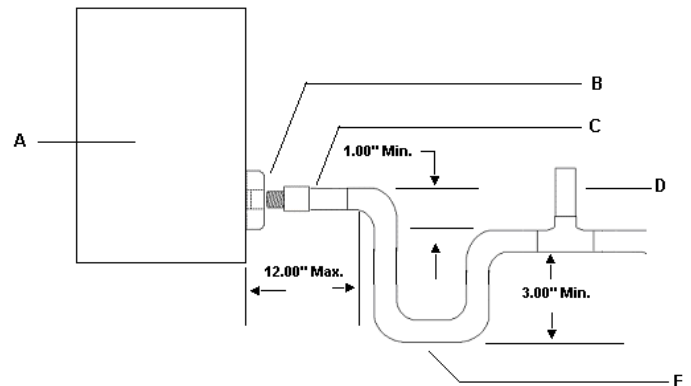

A. Air handler

B. Drain connection

C. Drain line

D. Anti-siphon air vent

E. Drain trap

NOTE: Do not operate air handler without drain trap. The condensate drain is on the negative pressure side of the blower; therefore, air being pulled through the condensate line will prevent positive drainage without a proper trap.

6. Route the drain line to the outside or to an appropriate drain. Drain lines must be installed so they do not block service access to the front of the air handler. A 24" clearance is required for filter, coil, or blower removal and service access.

NOTE: Check local codes before connecting the drain line to an existing drainage system.

7. Insulate the drain lines where sweating could cause water damage.

Test condensate drain pan and drain line after installation:

1. Pour several quarts of water into drain pan, enough to fill drain trap and line.
2. Check to make sure the drain pan is draining completely, no leaks are found in drain line fittings, and water is draining from the end of the primary drain line.
3. Correct any leaks found.

INSTALL DUCTWORK

IMPORTANT:

- Install ductwork in accordance with NFPA 90B and any local codes.
- Connect supply air duct to the flange on top of the air handler. If an isolation connector is used, it must be nonflammable.
- A return air duct system is recommended. If the unit is installed in a confined space or closet, a return

connection must be run, full size, to a location outside the closet.

Verify Orifice Size

NOTE: Some models are equipped with Thermal expansion valve and do not require any orifice change.

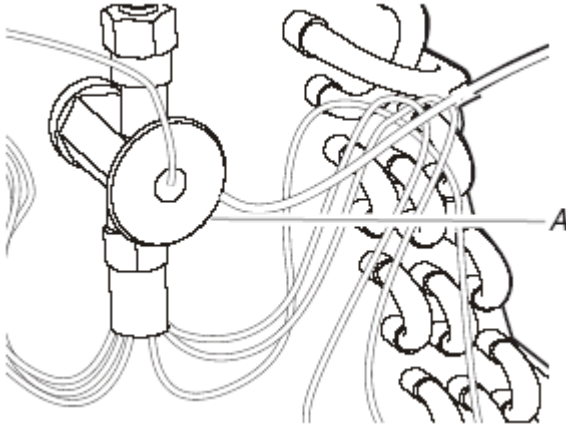

Thermal expansion valve

For factory installed thermal expansion valves you must, attach sending bulb to suction line with strap. Bulb should be positioned no further than 1 foot from header connection and situated at the 10 or 2 o'clock position. Secure tightly and cover with cork or foam insulation.

IMPORTANT: The proper orifice size is dependent on indoor coil/outdoor unit combination and application. The identification of the piston orifice size is located on a small white strip located on the liquid line inside the air handler.

1. Consult the outdoor unit information to determine whether the indoor unit has the correct orifice installed.
2. If a change of the orifice is required, loosen the brass hex nut and separate the orifice extension stub from the brass hex fitting.

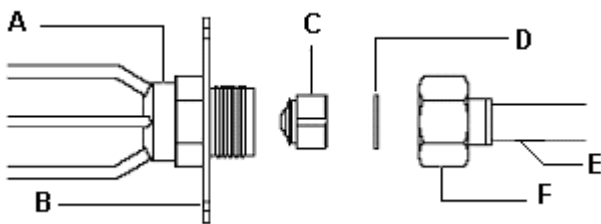

A. Distributor fitting
B. Mounting flange
C. Piston orifice

D. Ring seal (supplied)
E. Orifice extension bulb
F. 0.812" brass hex nut

3. Remove the orifice with an orifice extractor tool.
4. Insert the proper orifice into the fitting, seal end first. Make sure the orifice is free to move in the fitting.
5. Replace the brass hex nut.
NOTE: Over tightening (**1/4 turn past snug**) the brass hex nut will crush the gasket and may result in a system leak or stuck piston.
6. Dispose of all packaging and unused parts.

Connect Refrigerant Lines

Refrigerant lines must be connected by a licensed, EPA certified refrigerant technician in accordance with established procedures. **IMPORTANT:**

- Connecting refrigerant lines must be clean, dehydrated, refrigerant-grade copper lines. Air handler coils should be installed only with specific line sizes for approved system combinations.
 - Handle the refrigerant lines gently during installation process. Sharp bends or possible kinking in the lines will cause a restriction.
 - Do not remove the caps from the lines or system connection points until connections are ready to be completed.
1. Route the suction and liquid lines from the fittings on the indoor coil to the fittings on the outdoor unit. Run the lines in as direct a path as possible avoiding unnecessary turns and bends.
 2. Make sure that the suction line is insulated over the entire exposed length and that both suction and liquid lines are not in direct contact with floors, walls, ductwork, floor joists, or other piping.
 3. Connect the suction and liquid lines to the evaporator coil.
 4. To avoid damaging the rubber grommets in the cabinet while brazing, slide the rubber grommets over the refrigerant lines until they are away from the heat source.
 5. Braze with an alloy of silver or copper and phosphorus with a melting point above 1,100°F.
NOTE: Do not use soft solder.
 6. Reinstall the rubber grommets after brazing is finished.
 7. Make sure outdoor unit has been put in place according to the Installation Instructions and is connected to the refrigerant lines.

WARNING



Electrical Shock Hazard

Disconnect all power supplies before servicing.

Replace all parts and panels before operating.

Failure to do so can result in death or electrical shock.

Make Electrical Connections – Models Without Factory-Installed Electric Heat

240-Volt Installations

1. Disconnect all power supplies.
2. Remove the air handler access panel.
3. Route the field supply wires to the air handler electrical connection box.
4. Using UL listed wire nuts, connect the field supply wires to the air handler (black to black and yellow to yellow).

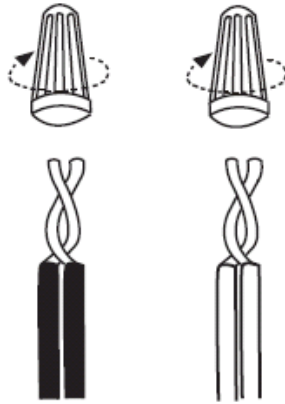

Make Electrical Connections – Models With Factory-Installed Electric Heat

1. Determine the number of circuits needed to supply the heater with electrical power (1, 2, or 3 circuits). See the air handler Accessory Kit label for number of circuits and ratings.
2. Disconnect all power supplies.
3. Knock out the correct number of knockouts (1, 2, or 3), and install UL listed wires and fittings.
4. Connect appropriate size wire to the circuit breaker terminals. If circuit breakers are not provided, a terminal block is provided.
5. Connect green ground wire(s) (1, 2, or 3) to ground terminal(s) (1, 2, or 3) marked "GND."

⚠ WARNING



Electrical Shock Hazard

Electrically ground air handler.

Connect ground wire to ground terminal marked "GND".

Failure to do so can result in death or electrical shock.

5. Connect ground wire to ground terminal marked "GND."

Connect to Circuit Breaker

NOTE: There are 2 ground terminals marked "GND" shown here. There may be 1, 2 or 3 ground terminals depending on the number of circuit breakers.

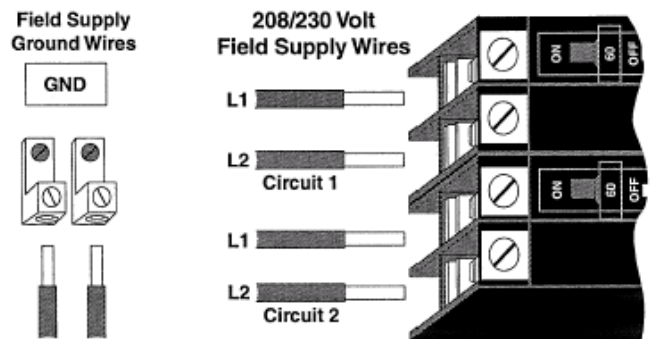

Connect to Terminal Block

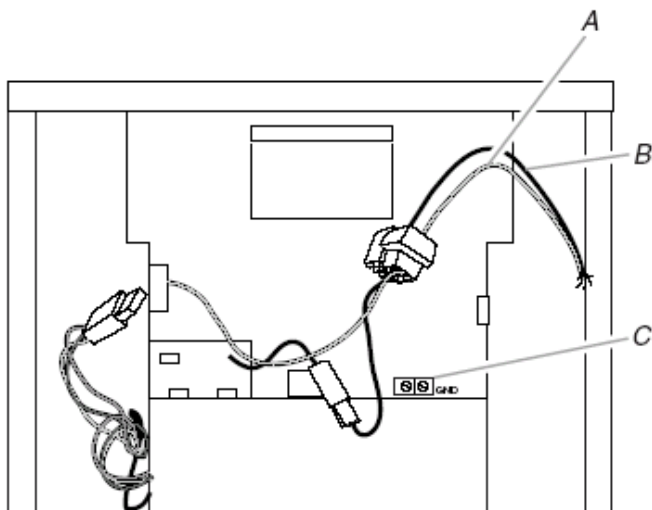
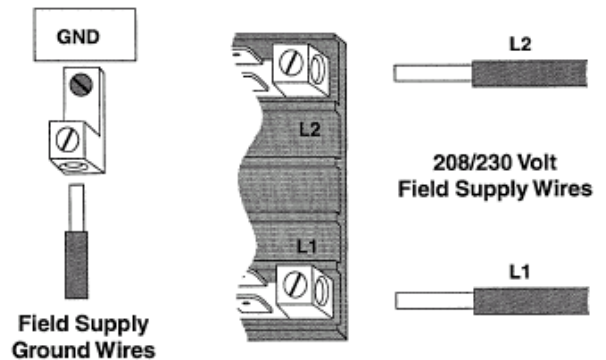

A. Connect yellow to yellow

B. Connect black to black

C. Connect ground wire to ground terminal marked "GND"

6. Replace the air handler access panel.

6. Install conduit-opening plugs in any unused openings.
7. If circuit breakers or pull disconnects are used, the front panel knockouts will need to be removed.
8. Reinstall the air handler blower access panel.
9. Reconnect power.
10. Dispose of/recycle all remaining parts.

208-Volt Conversion

1. Disconnect all power supplies.
2. Remove the air handler access panel.
3. Move the 2 connected black transformer leads from the 240-volt terminal on the transformer to the 208-volt terminal on the transformer. See "Wiring Diagram – Electric Heat and Blower."

Line Voltage Connections

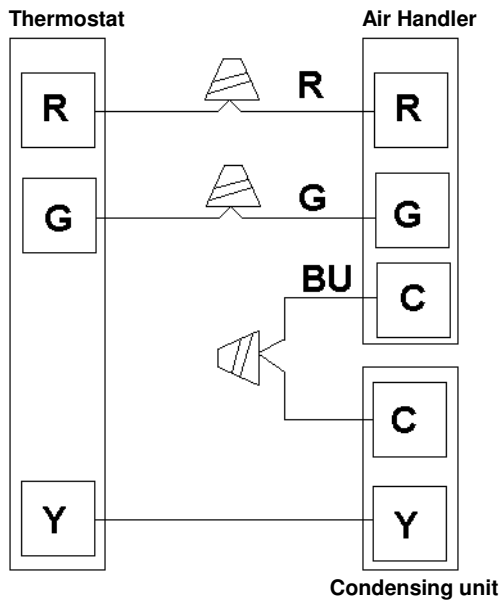

Cooling Only Application

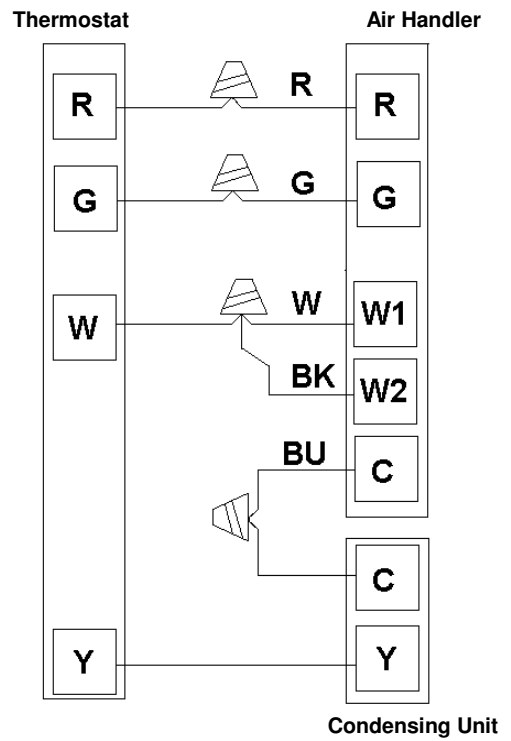

Cooling Application with Electric Heat

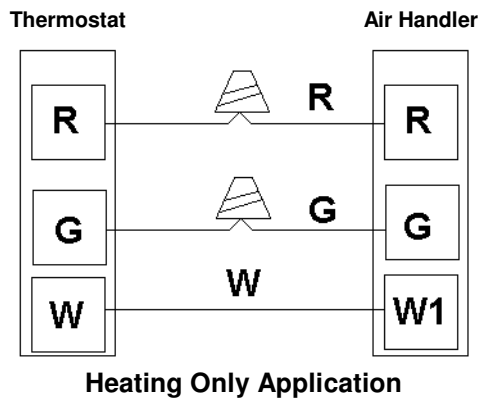

Heating Only Application

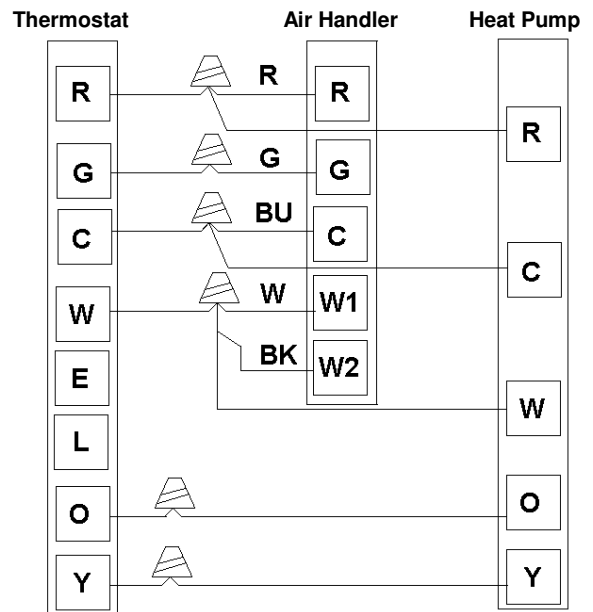

*Connect common (C) wire only if required. See Thermostat Installation Instructions.

Heat Pump Application with Electric Heat

Complete Installation

NOTE: Refer to outdoor unit installation instructions for system start-up instructions and refrigerant charging instructions.

PRE-Start Check

- Is unit properly located, level, secure, and serviceable?
- Has an auxiliary pan been provided under the unit with separate drain for units installed above a finished ceiling or in any installation where condensate overflow could cause damage?
- Have all webs been removed from the drain connections that are being used? Have all drain pan plugs not used been properly plugged?
- Has the condensate line been properly sized, run, trapped, pitched, and tested?
- Is the ductwork correctly sized, run, taped, and insulated?
- Have all cabinet openings and wiring been sealed?
- Is the indoor coil orifice size correct?
- Have all unused orifice replacement parts and packaging been disposed of?
- Is the filter clean, in place, and of adequate size?
- Is the wiring neat, correct, and in accordance with the wiring diagram?
- Is the unit properly grounded and protected (fused)?
- Is the thermostat correctly wired and in a good location?
- Are all access panels in place and secure?

Check Blower Operation

1. Set the thermostat to FAN ON.
2. The indoor blower should come on.

Check Electric Heater (if used)

1. Set thermostat to call for auxiliary heat (approximately 5°F above ambient temperature). The indoor blower and auxiliary heat should come on together. Allow a minimum of 3 minutes for all sequencers to cycle on.
2. Set the thermostat so it does not call for heat. Allow up to 5 minutes for all sequencers to cycle off.

Check Airflow

Cooling blower speed

- For proper cooling operation, the airflow through the indoor coil should be between 350 and 450 CFM per ton

of cooling capacity (or 350 – 450 CFM per 12,000 BTU/HR) based on the rating of the outdoor unit.

- The cooling blower speed is factory configured to provide correct airflow for an outdoor unit that matches the maximum cooling capacity rating of the air handler.
- If the outdoor unit is smaller than the maximum cooling capacity rating for the air handler, the cooling blower speed may need to be changed. Refer to Blower Performance Chart.

IMPORTANT: The cooling blower speed must be set to provide a minimum of 350 CFM airflow per ton (1,200 BTU/HR) of outdoor cooling capacity.



To change blower speed: Refer to “Wiring Diagram – Electric Heat and Blower.”

1. Disconnect all power supplies
2. Remove the air handler access panel.
3. Locate pin number 2 on the blower relay. Two black wires are connected to this terminal pin. One connects to pin number 5 on the blower relay; one connects to an inline splice connecting to a red or blue wire.
4. Remove the wire going to the 4-pin blower motor connector from the splice.
5. Connect the blower lead (Red (LO), Black (HI)) onto the splice from the 4-pin blower motor connector.
NOTE: Unused blower speeds are shipped from the factory covered with a plastic cap. Remove this cap from the new blower speed terminal and replace it over the factory –set blower terminal.
6. Replace all panels
7. Reconnect power.

Blower Performance Chart

Air Handler Model	Blower Speed	CFM @ESP. -in. W.C.				
		0.10	0.20	0.30	0.40	0.50
18	Low* (Red)	722	702	656	609	517
	Med (Blue)	994	926	838	707	626
	High (Black)	1036	958	873	779	663
24	Low (Red)	722	702	656	609	517
	Med* (Blue)	994	926	838	707	626
	High (Black)	1036	958	873	779	663
30	Low (Red)	929	916	890	842	737
	Med* (Blue)	1059	1043	1014	948	842
	High (Black)	1290	1271	1213	1153	1043
36	Low* (Red)	1135	1120	1112	1079	995
	Med (Blue)	1354	1345	1317	1260	1090
	High (Black)	1494	1469	1417	1336	1250
42	Low (Red)	1202	1192	1160	1116	998
	Med* (Blue)	1404	1413	1386	1303	1192
	High (Black)	1540	1530	1507	1386	1254
48	Low (Red)	1593	1582	1526	1444	1318
	Med* (Blue)	1759	1709	1636	1538	1395
	High (Black)	1886	1820	1742	1606	1446
60	Low (Red)	1782	1755	1672	1554	1393
	Med* (Blue)	2066	1960	1860	1714	1476
	High (Black)	2109	2067	1949	1770	1586

All data given while air handler is operating with a wet DX coil and air filter installed.
 Speeds marked in **bold with an asterisk*** are the factory settings for both heating and cooling.
 Cooling speeds should not be reduced below factory settings.
 Different speeds can be set for heating mode.

SEQUENCE OF OPERATION

Cooling (cooling only or heat pump)

When the thermostat calls for cooling, the circuit between R and G is completed, and the blower relay is energized. The Normally Open contacts close, causing the indoor blower motor to operate. The circuit between R and Y is also completed; this circuit closes the contactor in the outdoor fan motor. Circuit R and O energizes the reversing valve, switching it to the cooling position. (The reversing valve remains energized as long as selector switch is on the COOL position.)

Heating (electric heat only)

When the thermostat calls for heat, the circuit between R and W is completed, and the heater sequencer is energized. A time delay follows before the heating elements and the indoor blower motor comes on. Units with a second heat sequencer can be connected with the first sequencer to W on the thermostat subbase or connected to a second stage on the subbase.

Heating (heat pump)

When the thermostat calls for heat, the circuits between R and Y and R and G are completed. Circuit R-Y energizes the contactor

starting the outdoor fan motor and the compressor. Circuit R and G energizes the blower relay starting the indoor blower motor. If the room temperature should continue to fall, the circuit between R and W1 is completed by the second stage heat room thermostat. Circuit R-W1 energizes a heat sequencer. The completed circuit will energize supplemental electric heat (if applicable). Units with a second heater sequencer can be connected with the first sequencer to W1 on the thermostat or connected to a second heating stage W2 on the thermostat subbase.

Emergency Heat (heating heat pump)

If selector switch on thermostat is set to the emergency heat position, the heat pump will be locked out of the heating circuit, and all heating will be electric heat (if applicable). A jumper should be placed between W2 and E on the thermostat subbase so that the electric heat control will transfer to the first stage heat on the thermostat. This will allow the indoor blower to cycle on and off with the electric heat when the fan switch is in the AUTO position.

AIR HANDLER MAINTENANCE

At the beginning of each heating season the unit should be serviced by a qualified installer or servicing agency.

IMPORTANT: Do not operate system without a filter. A filter is required to protect the coil, blower, and internal parts from excessive dirt and dust. See "Installation Configurations" for the location of the filter in the unit cabinet and the service panel giving access to unit filter. The filter is placed in the air return duct by the installer.

- Inspect air filters at least once a month and replace or clean as required. Dirty filters are the most common cause of inadequate heating or cooling performance.

- Replace disposable filters. Cleanable filters can be cleaned by soaking in mild detergent and rinsing with cold water.
- Do not replace a cleanable (high velocity) filter with a disposable (low velocity) filter unless return air system is properly sized for it.
- If water should start coming from secondary drain line, a problem exists which should be investigated and corrected. Contact a qualified person.

ASSISTANCE OR SERVICE

If you need further assistance, you may contact your local dealer.

Accessories

To order accessories ask for the appropriate part number listed below or contact your local dealer.

Description	Part Number	Description	Part Number
5 KW with Pigtail ends	65500901	20 KW with Circuit Breaker	65500911
5 KW with Terminal Block	65500902	Downflow Kit (1.5, 2, 2.5, & 3 ton)	65873175
5 KW with Circuit Breaker	65500903	Single Point Breaker Kit for 2 Stage	110001055
7.5 KW with Circuit Breaker	65500904	Single Point Breaker Kit for 3 Stage	110001054
7.5 KW with Terminal Block	65500905		
10 KW with Terminal Block	65500906		
10 KW with Circuit Breaker	65500907		
15 KW with Circuit Breaker	65500909		

Electric Heat Kits

Refer to the Accessory Kit Label on the front panel of the air handler for electric heat kit accessory options and applications.

Air Handler Limited Warranty

General Five Year Parts Warranty: This equipment will perform at installation according to its specifications when installed, operated, repaired and serviced in strict accordance with the installation and maintenance instructions and using authorized service parts. This warranty applies only to equipment installed within the United States and Canada.

If within five (5) years from the date of original installation any covered parts fail because of a manufacturing defect, the manufacturer will provide a replacement part. You are responsible for all other costs of warranty service. The manufacturer assumes no responsibility for any costs associated with the replacement of this part. The costs of refrigerant, refrigerant reclaiming, driers, filters, belts or freight charges along with miscellaneous material charges are not covered. Such costs may be covered by a separate warranty provided by the installing dealer or contractor. Replacement of failed parts by the manufacturer will be provided through a qualified servicing dealer or contractor. The manufacturer must receive written documentation of annual preventative maintenance, for this warranty to be valid. This should include a record of normal maintenance as outlined in the installation and servicing instructions or the owners manual, including all cleaning, lubrication and standard replacement.

Use of this product other than in a single-family residential application will limit the warranty to one (1) year for covered parts.

Covered parts include all parts of this unit except for the following Excluded Components, which are not covered by this warranty: cabinets, cabinet pieces, wiring and wiring harnesses.

This warranty will begin on the date of original installation whether or not the actual use begins on that date. If the date of original installation cannot be verified, the warranty will be deemed to begin six (6) months after the date of manufacture.

Warranty Procedure – When warranty parts are required, you should contact a qualified local contractor or dealer, and be prepared to provide the following information: complete model and serial number and date of installation, and an accurate description of the problem.

Limitation of Warranties - The manufacturer makes no express warranties other than the warranties set forth above. All implied warranties, including the implied warranties of merchantability and fitness for a particular purpose are excluded to the extent legally permissible, or are limited to a period of one (1) year. Should such exclusion or limitation of warranty be unenforceable, such implied warranties are in any event limited to the duration of the express warranty, set forth above. Liability for incidental, punitive and/or consequential damages is excluded. Some states do not allow limitations on how long an implied warranty lasts or the exclusion or limitations of incidental, punitive or consequential damages, so the limitations or exclusions may not apply to you.

This warranty gives you specific legal rights, and you may also have other rights, which vary from state to state.

Conditions of Warranty - The furnishing of replacement parts under the terms of this warranty will apply to the original warranty period (including any extended warranty period) and will not serve to extend such period. This warranty is voided if the equipment is removed from the original installation site.

This warranty does not apply to damage or defect resulting from:

- Accident, or negligent or unreasonable use or operation of the equipment, including operation beyond rated capacity and operation of electrical components at voltages other than the rate specified in the nameplate.
- Modification, changes or alterations of the equipment, except as directed by the manufacturer.
- Operation with system components, which do not match combinations listed in the Air Conditioning and Refrigeration Institute (ARI) Director of Certified Unitary Equipment or operation of this system with refrigerants other than as specified in the installation instructions.
- Damage as a result of flood, winds, fires, lightning, or exposure to corrosive elements or a corrosive environment (such as salt, chlorine, fluorine, or other damaging chemicals).